

Construction and Testing of an Accelerated Bridge Construction Project in Boone County

Ryan Bowers
Iowa State University
394 Town Engineering Building
Ames, IA 50011
rpbowers@iastate.edu

F. Wayne Klaiber
Iowa State University
422 Town Engineering Building
Ames, IA 50010
klaiber@iastate.edu

Samantha Kevern
Walter P. Moore and Associates
920 Main Street, 10th Floor
Kansas City, MO 64105
SKevern@walterpmoore.com

Cole Landau
Iowa State University
394 Town Engineering Building
Ames, IA 50011
clandau@iastate.edu

Robert Kieffer
Boone County Engineer
Boone County Courthouse
201 State Street
Boone, IA 50036
BobK@co.boone.ia.us

James S. Nelson
Office of Bridges and Structures
Iowa Department of Transportation
800 Lincoln Way
Ames, IA 50010
James.S.Nelson@dot.iowa.gov

ABSTRACT

New bridge systems are needed that will allow components to be fabricated off-site and transported to the bridge site for quick assembly with minimal disruption to the traveling public. Depending on the specific site conditions, the use of prefabricated bridge systems can minimize traffic disruption, improve work zone safety, reduce the impact on the environment, improve constructability, increase quality, and lower life-cycle costs. This technology is applicable and needed for both the rehabilitation of existing bridges and the construction of new bridges. The Federal Highway Administration (FHWA) has recently developed a program to promote accelerated construction through the use of precast bridge elements.

This paper will present the construction process, construction schedule, and laboratory testing for one of the first applications of an accelerated bridge project utilizing precast components in the state of Iowa. Through the FHWA Innovative Bridge Research and Construction program, a bridge in Boone County, Iowa was constructed using several different precast, high-performance concrete elements.

Researchers from Iowa State University performed laboratory testing on the precast components that were used in the Boone County bridge. Field instrumentation and testing was used to verify the post-tensioning operation and to verify several of the construction methods. The laboratory portion of this investigation was funded by the Iowa Department of Transportation (Iowa DOT) and the Iowa Highway Research Board. Also, a comparison of the actual construction schedule with a theoretical schedule was completed. A discussion of the laboratory testing, structural instrumentation, monitoring, and scheduling of this innovative bridge is presented in this paper.

Key words: accelerated construction—bridge replacement—precast bridge elements—precast pier and abutment caps—post-tensioned

INTRODUCTION

Constructing and rehabilitating bridges with minimal impact on traffic has become a transportation priority as traffic volumes nationwide increase. Renewal of the infrastructure in the United States is necessary for several reasons, including increases in population, projected increase in vehicle miles traveled, presence of obsolete or deficient structures, impact of road construction, and injuries and fatalities related to work zones (NCHRP 2003).

Rapid construction has several advantages over traditional construction methods. The six main advantages of rapid construction technology are

- Minimized traffic disruption
- Improved work zone safety
- Minimized environmental impact
- Improved constructability
- Increased quality
- Lowered life-cycle cost (NCHRP, 2003)

There are several different types of rapid construction technologies currently used in the United States. One technology uses precast concrete bridge components that are fabricated offsite, allowed to cure, and then transported to the construction site for installation. This technology allows bridges to be constructed faster than traditional construction methods, reducing the amount of time the bridge and/or associated roads are closed to the public, and reducing the total construction time. For bridges above waterways, the construction time is also reduced; thus the amount of debris that falls from the construction site is reduced, which in turn reduces the environmental impact.

The importance of rapid construction technologies has been recognized by the FHWA and the Iowa DOT Office of Bridges and Structures. This paper presents some of the results from the construction of a new accelerated construction precast bridge system located in Boone County, Iowa and evaluation of bridge components tested in the laboratory. Funding for the design, construction, and evaluation of this project was provided by the FHWA-sponsored Innovative Bridge Research and Construction (IBRC) Program. Funding for the laboratory testing was provided by the Iowa DOT and the Iowa Highway Research Board; funding for the documentation and the post-tensioning monitoring and verification was provided by the FHWA and Boone County.

This research focused on the bridge constructed on 120th Street in Boone County over Squaw Creek; the bridge replaced an existing Marsh Arch bridge at the site. The new bridge is a continuous, four-girder, three-span bridge with a full-depth, precast deck. Bridge dimensions are 151 ft. and 4 in. long and 33 ft. and 2 in. wide with spans of 47 ft. and 5 in., 56 ft. and 6 in., and 47 ft. and 5 in. Deck panels (8 in. thick, 8 ft. and 1 in. wide, and half the width of the bridge (16 ft. and 1 in.) in length), were prestressed in the transverse direction. Each panel had two full-depth channels, located over the prestressed girders, for longitudinal post-tensioning. Once the panels were erected, the entire bridge deck was post-tensioned in the longitudinal direction, after which concrete was cast in the four post-tensioning channels. Although this exact design had not been previously constructed, a similar partial-depth deck system has been constructed and tested in Nebraska (Badie, Baishya, and Tadros 1998). Precast pier caps and precast abutments were used in the bridge substructure.

BRIDGE CONSTRUCTION

Precast Fabrication

The fabricator selected by the general contractor to produce the precast elements for the Boone IBRC Bridge project was Andrews Prestressed Concrete, Inc. located in Clear Lake, Iowa. Andrews is a PCI certified plant and commonly fabricates Pretensioned Prestressed Concrete (PPC) beams for Iowa DOT projects.

Andrews initially cast three test panels that were purchased by Iowa State University (ISU) for their laboratory testing program. Prior to shipment to ISU, one of the test panels was used by the contractor to conduct a leveling device test. This test was required by the contract documents for the leveling device that was designed by the contractor. The selected leveling device operates as a screw jack; the deck panel transverse reinforcing bears on a steel plate with a nut welded to the bottom of the plate and a screw passing through the plate and nut. A pipe wrench was used to turn the screw to raise and lower the deck panel. The contractor demonstrated that the device was stable while supporting the deck panel over the PPC beam and could be adjusted to the desired elevation and deck cross slope. Once the leveling device was accepted, the bridge deck panels were fabricated.

Three deck panels could be cast in one casting operation. Panels could be fabricated every other day with a maximum of nine panels cast per week. Andrews fabricated reusable steel forms shown in Figures 1 and 2; the panels were cast on a steel casting bed in the open.



Figure 1. Panel forms and reinforcing



Figure 2. Panel form release

The anchorage zone was very short for the development of the pretensioning strands. Thus, spiral reinforcing was used to reinforce the bursting zone. Use of spiral reinforcement also improved strand development (see Figure 3). At the longitudinal centerline of the bridge, a longitudinal joint was cast in place. Reinforcement of the longitudinal joint was provided with double hairpin bars projecting from the panels, shown in Figure 4, and straight reinforcing bars threaded longitudinally. One benefit of a cast-in-place longitudinal joint at the centerline was to allow the panels to be cast flat and introduce the bridge crown in the longitudinal joint. The longitudinal joint at the centerline of the bridge did not add any construction time to the critical path because the longitudinal joint was cast concurrently with the open channels over the four beams after the post-tensioning.



Figure 3. Spiral reinforcing



Figure 4. Longitudinal joint reinforcing

For the vertical reinforcing connection in the coral style barrier rail, the contractor was given the option in the plans to project the reinforcing bars from the deck or use mechanical splicers; the contractor and fabricator chose the mechanical splicer option. End panels contained welded wire reinforcing and the post-tensioning anchorage zone. Concrete consolidation during panel concrete casting was closely monitored due to reinforcement congestion, especially due to the spiral reinforcing and welded wire reinforcing. No problems were detected in the consolidation and the concrete flowed well into the spiral reinforcing zone. A concrete strength of 4,000 psi was required for panel release which was easily achieved in 24 hours. The panels were released from the forms and stockpiled at the precast fabricator's yard to await shipment to the bridge site. Andrews was also the fabricator for the PPC beams, pier caps, and abutment caps for the project. Beams used were Iowa Standard "B" beams modified for a wider spacing than the typical standard beam spacing.

Substructure

Precast abutment caps and precast pier caps founded on H-piling and pipe piling, respectively, comprised the substructure. The units were reinforced with mild reinforcing and included blockouts for the piling that were created using corrugated metal pipe (CMP). During the design process, no research was found regarding the pile connection detail considering a bond or development of resistance between concrete and the CMP. A fairly conservative connection design was completed which was later validated by testing. The contractor had an end of driving tolerance of three in. in any direction for each H-piling in order to fit the precast abutment cap over the H-piling. Standard specifications typically only specify a start of driving tolerance for H-piling. Special plan notes were included to specify the end of driving tolerance. Care was taken during the pile driving operation, and the contractor had no problem meeting the end of pile driving tolerance or fitting the precast abutment cap over the H-piling shown in Figures 5 and 6; time required to set a single precast abutment cap was less than 30 minutes.

There were five H-piling supporting the abutment caps and nine 16 in. diameter pipe piling supporting the pier caps. The pier cap end of driving tolerance was 2 1/2 in. A driving template was fabricated that helped the contractor meet the end of driving tolerance so that the precast units fit over the piling. No problems were encountered, and the pipe piles were all well centered within the pier cap.



Figure 5. Setting precast abutment



Figure 6. Abutment CMP blackout

A high early strength concrete mix was used for filling the substructure blockouts. The concrete was cast with a maximum slump of two inches prior to adding a high-range water reducer (HRWR) to improve workability. With the HRWR the maximum slump allowed was seven in. Prior to PPC beam placement the concrete was required to achieve a 3,500 psi compressive strength.

Superstructure

The superstructure for the bridge utilized traditional PPC beams. Beams were modified from the standard design in order to eliminate a beam line. A standard bridge for the county would have a five-beam cross section and that was reduced to a four-beam cross section. To modify the beams, additional prestressing strands were added and the concrete release and 28-day strengths were increased.

Erection of the PPC beams was started early in the morning and completed shortly after noon. The day following the PPC beam erection the deck panel delivery (three per truck load) was scheduled. Panels were offloaded to a storage area and then erected. Half of the panels were scheduled for delivery the first day with the remainder scheduled for the following day. Panel delivery was divided in half because the contractor had not performed an operation like this before and did not know how long the panel erection would take.

The first half of the deck panel erection took the whole day. Panels were erected from the centerline of the bridge working outward (see Figure 7). Erection of the second half of the panels took half of the day. The primary difficulty erecting the deck panels is the alignment of the first deck panel erected. Once the first panel is properly positioned, the remaining panels were uniformly offset 3/8 in. and maintained the correct alignment. Panel leveling devices were installed the same day the deck panels were erected, as shown in Figure 8.

Transverse joints were cast in place with a high early strength concrete mix. Due to the tight deck panel spacing, a small aggregate size was used with a maximum top size of 3/8 in. Maximum water cement ratio was 0.38 and the slump was increased using a HRWR that allowed the slump to go to a maximum of eight in. A retarding admixture was used as well that seemed to extend the life of the HRWR for workability.



Figure 7. Deck panel erection



Figure 8. Leveling device installation

During the curing of concrete in the transverse joints, the post-tensioning strands were threaded through the end anchorages and down the channels for a total of 48 strands to post-tension. Each of the four channels contained twelve 0.6 in. diameter strands. The bridge was short enough to allow for post-tensioning from one end. Less than four hours was required to complete the entire post-tensioning operation. All the strands, except one, were post-tensioned with no problems. One strand became pinched between an adjacent strand and “extra” deck panel concrete. This strand was released and fully post-tensioned by applying the post-tensioning force from the opposite end of the bridge. The correct post-tensioning force application in that strand was doubly verified by gage pressure and summing the total strand elongation at each end.

Post-tensioning forces were verified by calibrated gage pressure. Strand elongation was checked as a final confirmation, shown in Figure 9. The jack stroke length was monitored during post-tensioning as a safety precaution against over tensioning.



Figure 9. Strand elongation check



Figure 10. Casting longitudinal joints

Concrete was cast in the longitudinal joints on the same day the post-tensioning force was applied, shown in Figure 10. As shown in Figure 11, the same concrete mix used for the transverse joints was used for the longitudinal joints. The longitudinal joints were congested with post-tensioning strands, transverse mild reinforcing, transverse prestressing strands, stirrups, and leveling plates with leveling screws.

The HRWR was very effective in aiding in the placement of the concrete. Concrete consolidation observed in the longitudinal channel haunch area, shown in Figure 12, and between the strands and reinforcing was excellent. Following the curing of the longitudinal joint concrete the leveling screws were “backed out” and the hole was filled with a hydraulic cement grout.



Figure 11. Channel congestion

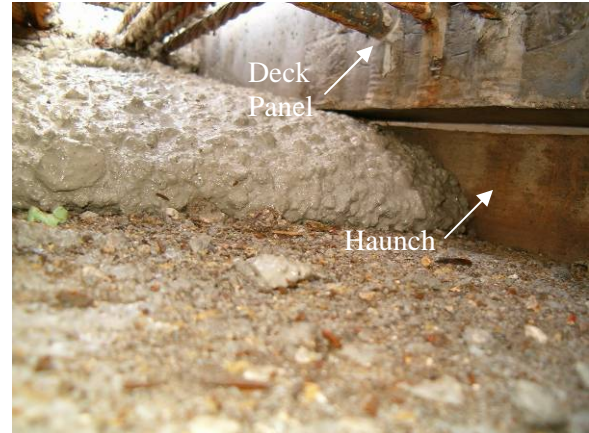

Figure 12. Concrete consolidation in haunch

A cast-in-place concrete diaphragm and deck end section was constructed to complete the integral abutment. The cast-in-place end section also allowed for panel erection tolerance; the total length of the deck panel portion of the bridge was nine inches longer than anticipated in the plans because the panels were fabricated on the high end of the dimensional fabrication tolerances.

To complete the bridge, the corral style barrier rail was cast in place, and the deck was ground for smoothness and grooved for texture prior to opening the bridge to traffic. Figures 13 and 14 show the completed bridge.



Figure 13. Bridge profile



Figure 14. Bridge approach

CONSTRUCTION SCHEDULE

Researchers on the Boone IBRC Bridge project have examined the Iowa DOT's *Weekly Report of Working Days* for the project and have created both an actual and a theoretical schedule that reflects production rates observed during the project. Both schedules have been compared and comments have been provided.

Actual Work Schedule

The Boone IBRC Bridge had a late project start date of July 5, 2006, and was specified 80 working days for contractual completion. September 8, 2006, is the date the contractor's bridge crew actually moved on site with 50 working days remaining for contractual completion. On December 28, 2006 the final task of the Boone IBRC Bridge construction was completed. A total of 90 working days were required for the project, 10 days beyond the contractual allowance. *The Weekly Report of Working Days* for the Boone IBRC Bridge from September 8, 2006 to December 28, 2006 revealed that there had been 2.5 days where the contractor was charged with a working day but did no work. Also revealed in the *Weekly Report* was that between the dates of July 5, 2006 and September 8, 2006 there had been four days the contractor was charged a working day but did no work. In total, the contractor was charged with 6.5 non-productive working days. Ultimately, the contractor was charged liquidated damages for the 10 working days over the contractual allowance of 80 days.

Theoretical Work Schedule

The theoretical schedule developed by the researchers was based on the assertion that the existing structure would have been previously removed and the abutment berms for the new structure would be in place. Durations of construction activities utilized in the theoretical schedule were obtained from actual durations observed at the Boone IBRC Bridge. It was observed by the researchers that some of the activities of construction could occur parallel or even before the initiation of onsite construction. With all of these factors taken into consideration the researchers determined that a similar structure to the Boone IBRC Bridge could be assembled in 12 working days. Cure times for any cast-in-place concrete elements is not included in arriving at the 12 working day value.

Comparison of Actual vs. Theoretical Work Schedules

A brief comparison of the actual work schedule to that of the theoretical schedule was performed. The researchers found that in theory the structure could have been assembled 48 working days ahead of the actual schedule. When the structure was constructed in the summer and fall of 2006 it took 90 working days to complete. However, only 60 of those working days were directly related to assembly of the structure (i.e. after September 8, 2006). The other 30 working days had been utilized to construct portions of the project not directly associated with bridge assembly. Because the contractor, material suppliers and engineers had never constructed a project like the Boone IBRC Bridge, there were many Requests for Information (RFI) that required answers and, therefore, the construction took longer than predicted by the theoretical schedule. In future projects contractors, material suppliers, and engineers alike will be more adapt to the accelerated construction and delivery method used at the Boone IBRC Bridge.

LABORATORY TESTING

Laboratory tests were performed on several components of the bridge substructure and superstructure. The substructure tests were performed on sections of the abutments and pier caps, and isolated shear tests of the pile connection to the abutments. Superstructure testing included deck panel testing and testing of the flowability of the concrete used in the post-tensioning channels.

Substructure Testing

A series of laboratory tests were performed by ISU to verify the strength of the abutment section before bridge construction began. Tests were performed to ensure that punching shear failure would not occur in the abutment before the CIP cap was placed. In order to verify the design strength, a ten ft. section of the abutment and pier cap was tested in the laboratory; the section of the abutment the test specimen replicates can be seen in Figure 15.

Simulated beams were fabricated out of concrete and placed on the laboratory floor. Neoprene bearing pads were placed on top of the simulated beams, and the specimens were placed on the bearing pads. In this configuration, the pile extended upwards and was loaded from above. One of the test specimens, situated under the load frame prior to loading, is shown in Figure 16. Note the specimens were inverted for stability when tested.

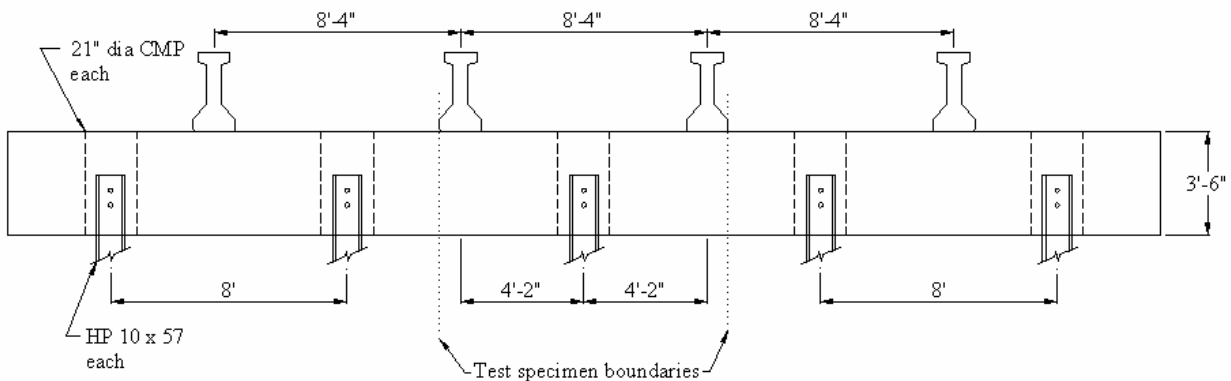

Figure 15. Side view of the precast abutment and laboratory test section

Similar tests were performed on the inverted pier cap specimen using a ten ft. section of the pier cap. Each specimen used the appropriate cross section and pipe pile for the pier caps, but otherwise used the same laboratory testing system as was used for the abutment testing.

In total, eight laboratory pile and abutment tests were performed. The average strength of the abutment specimens and pier cap specimens, along with the unfactored service loads for each is presented in Table 1. In addition to the described tests, shear tests were performed on four H-pile and CMP connections; each of the shear tests was loaded to 400 kip without cracking or appreciable differential movement. Based on the laboratory test results, punching shear failure was determined not to be of concern for the abutments or pier caps in the field.



Figure 16. Laboratory testing system

Table 1. Service load and experimental specimen strengths

Specimen	Unfactored Service Load (kip)	Average Maximum Load (kip)
Abutment	80	382
Pier Cap	72	384

Superstructure Testing

Laboratory tests were conducted to determine the flexural and punching shear capacity of the deck panels. Panels were designed for HS-20 loading. Because of the localized failure for each test, multiple tests were conducted on the specimen since previous tests on the specimen had minimal influence on the additional tests. Setup of the deck panels and locations of the three loads are shown in Figure 17. Construction of the test setup included placing each panel on two beams, placing steel for the closure joint, and casting concrete for the longitudinal and closure joints.

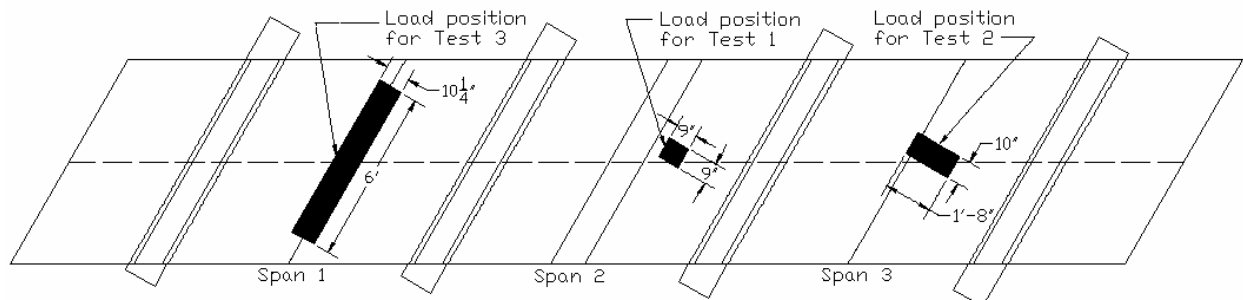

Figure 17. Load locations and footprints for bridge deck load tests

Span 2 was the first span tested. A nine in. square footprint was chosen for this test to have consistency with the service load tests previously conducted. In order to introduce shear into the closure joint and increase the probability of a failure, the load was not centered over the joint. A punching shear failure occurred at 150 kips.

Span 3 was tested second. For this span, a tandem wheel footprint was chosen so the bridge would be subjected to the standard design footprint. Also, use of this footprint gave the opportunity to see if punching shear would control in the field for the actual bridge. At a load of 150 kips, concrete began spalling from the surface of the deck panel. When the load reached 157 kips, a combination of flexural and punching shear failure occurred.

In order to determine the flexural capacity of the deck panel, a beam was placed across the center of Span 1 to act as a line load. The beam was positioned to be parallel to the support beams for the deck panels. The load beam was 6 ft. long and 10.25 in. wide. A flexural failure occurred at a load of 196 kips.

CONCLUSIONS

The following were concluded from this project:

- Placement of a single precast pier cap or abutment cap could be done in less than 30 minutes because piles were driven within tolerances.
- Deck panels for half the bridge could be erected in half of a day.
- Construction began on July 5 and was completed on December 28, requiring a total of 90 working days.
- A theoretical work schedule predicted that the Boone IBRC Bridge could be assembled in 12 working days.
- The abutment connection capacity is at least 4.5 times greater than the unfactored service load.
- The pier cap connection capacity is at least 5.3 times greater than the unfactored service load.
- Deck panels failed due to a combination of flexure and punching shear at a load of 157 kips applied by a tandem wheel footprint.

ACKNOWLEDGMENTS

The research presented in this paper was made possible through funding from the Iowa DOT, the Iowa Highway Research Board, and the FHWA. We would like to thank the aforementioned entities for the opportunity to work on this project. We would also like to thank the numerous ISU graduate and undergraduate students for their help with both the laboratory and field testing portions of this project.

REFERENCES

- Badie, S.S., M.C. Baishya, M.K. Tadros. 1998. NUDECK: An Efficient and Economical Precast Prestressed Bridge Deck System. *PCI Journal*, 43(5), 56–71.
- NCHRP. 2003. *Detailed Planning for Research on Accelerating the Renewal of America's Highways (Renewal)*. NCHRP Project 20-58(1). Preliminary Draft Final Report. Washington, DC: National Cooperative Highway Research Program.