

Homework #1 (Due Oct. 9)

- Identify the region of operation of an NMOSFET with $V_{TO} = 1$ V. Assume $V_{SB} = 0$.
 (a) $V_{GS} = 5$ V, $V_{DS} = 6$ V, (b) $V_{GS} = 0$ V, $V_{DS} = 6$ V, (c) $V_{GS} = 2$ V, $V_{DS} = 2$ V, (d) $V_{GS} = 1.5$ V, $V_{DS} = 0.5$ V, (e) $V_{GS} = 2$ V, $V_{DS} = -0.5$ V, (f) $V_{GS} = 3$ V, $V_{DS} = -6$ V.
- Find the region of operation and the drain current of a PMOSFET with $W/L = 1$, $k' = 25 \mu\text{A}/\text{V}^2$, $V_{TO} = -0.9$ V and $V_{SB} = 0$. (a) $V_{GS} = -1.1$ V, $V_{DS} = -0.3$ V and (b) $V_{GS} = -1.3$ V, $V_{DS} = -0.3$ V.
- For this problem use the following parameters
 n-ch: $V_{TO} = 0.7$ V, $k' = 100 \mu\text{A}/\text{V}^2$, $\gamma = 0.6 \text{V}^{1/2}$, $\phi = 0.7$ V, $\lambda = 0 \text{V}^{-1}$
 p-ch: $V_{TO} = -0.9$ V, $k' = 25 \mu\text{A}/\text{V}^2$, $\gamma = 0.5 \text{V}^{1/2}$, $\phi = 0.7$ V, $\lambda = 0 \text{V}^{-1}$

Determine the unknown quantities (shown with ?) in the MOSFET configurations shown below. Use SPICE with the Level-1 MOSFET model to verify your answers.

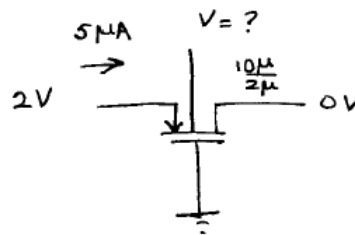
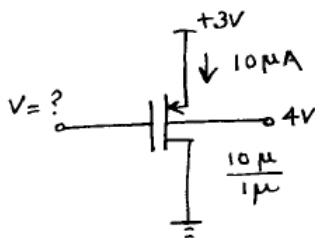
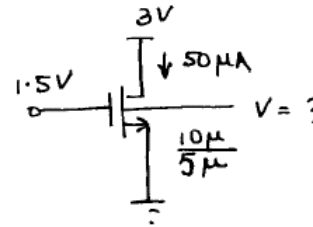
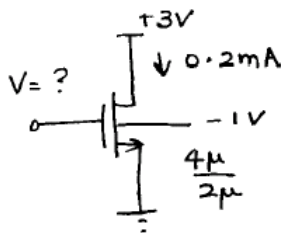
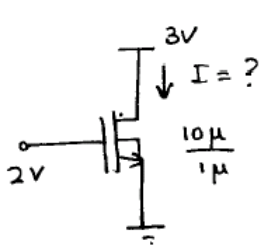

4. For the circuits shown below determine V_O for the condition $V_i = V_o$. Your answer should be in terms of β_1 , β_2 , β_3 , V_{DD} , and V_T where $\beta = k' \frac{W}{L}$, $V_{TN} = |V_{TP}| = V_T$. Assume V_{DD} is large enough to properly bias these circuits. Assume $\lambda = \gamma = 0$.

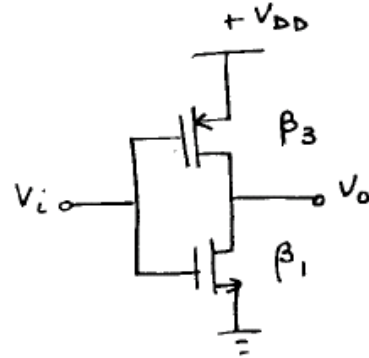
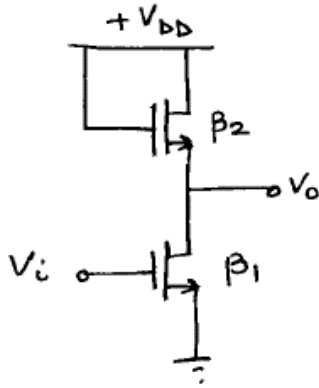

5. a) Plot the following data and graphically determine V_{T0} and $k' \frac{W}{L}$. $V_{DS} = 3.0V$ and

$$V_{SB} = 0V.$$

$V_{GS}(V)$	1.6	1.8	2.0	2.2	2.5
$I_D(\mu A)$	25	49	81	121	169

- b) Given the following data determine γ . Assume $\phi = 0.7V$.

$V_{SB}(V)$	0	1.0	2.0	3.0
$V_T(V)$	0.5	1.05	1.45	1.75

- c) Determine λ based on the following data measured in the saturation region.

$V_{DS}(V)$	1.5	2.0	2.5	3.0
$I_D(\mu A)$	104	106	107	109