

# Using Google SketchUp – Part 2

Mike Bailey

mjb@cs.oregonstate.edu

<http://cs.oregonstate.edu/~mjb/sketchup>

Oregon State University

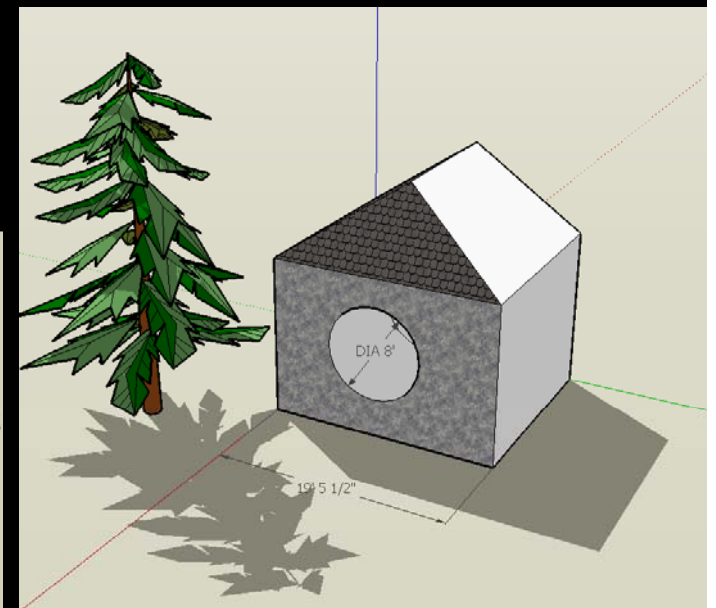
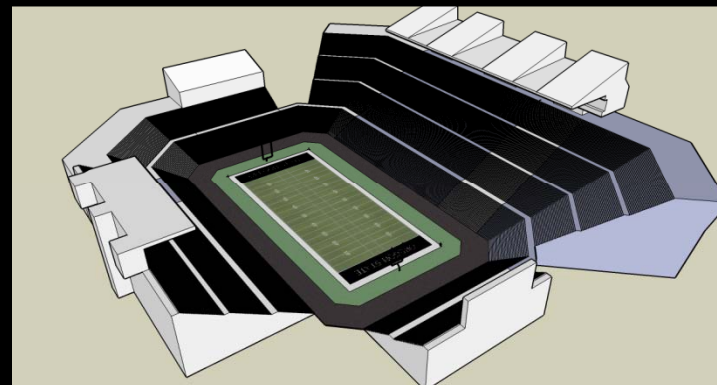

OSU

Oregon State University  
Computer Graphics

## Getting Started

Double-click the Google SketchUp icon  
or click:

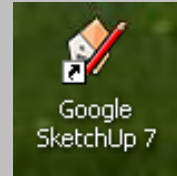

**Start → All Programs → Google SketchUp 7 → Google SketchUp**

The start screen should look something like this:

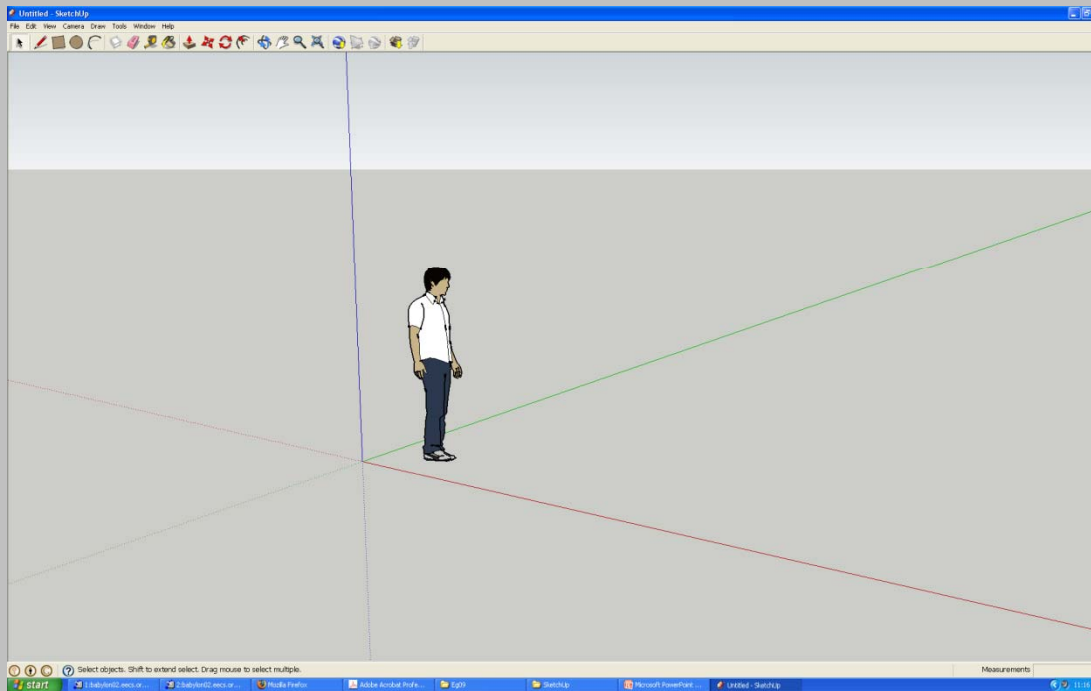

Right now, click **File**→**Save As** – and hit Save often while you are editing

## Getting Started Toolbar

The icons across the top are *really* important:

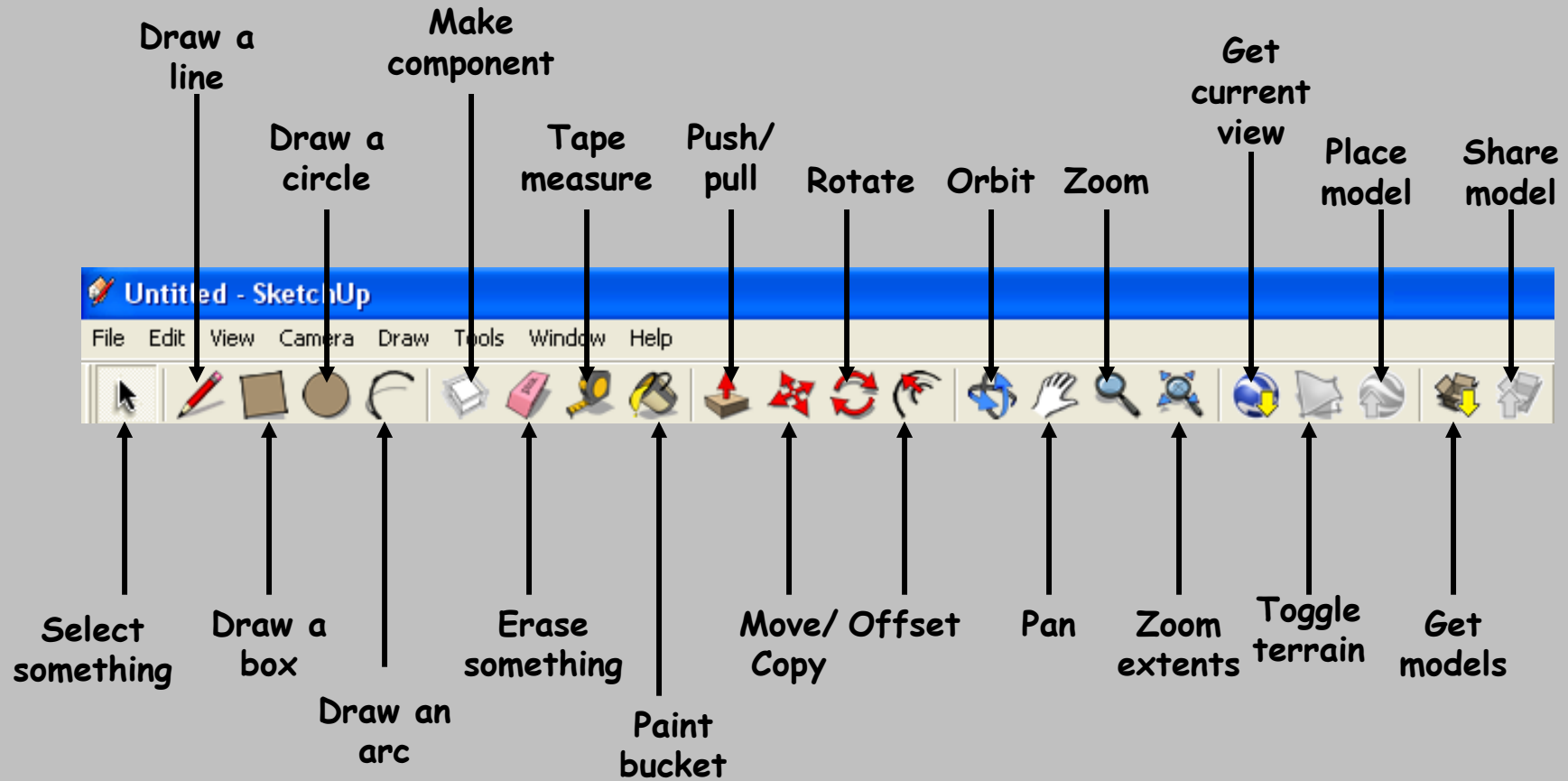

## The Large Toolset Toolbar

Select **View**→**Toolbars**→**Large Tool Set**



## The Views Toolbar

Select **View**→**Toolbars**→**Views**

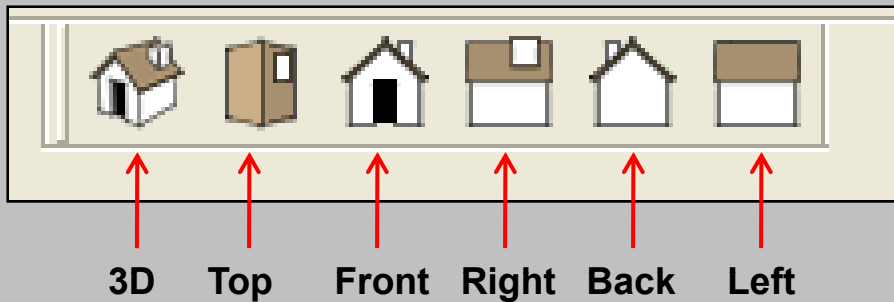

This is a *very* handy toolbar to have active because it lets you change to a specific view of your scene with one mouse click!

## SketchUp “Inferences”

One of SketchUp’s key strengths is that it doesn’t require you to enter every little piece of information as many 3D computer programs do. Instead, it tries to infer what you really mean by how you do things. Oftentimes it uses colors to tell you what it is inferring.

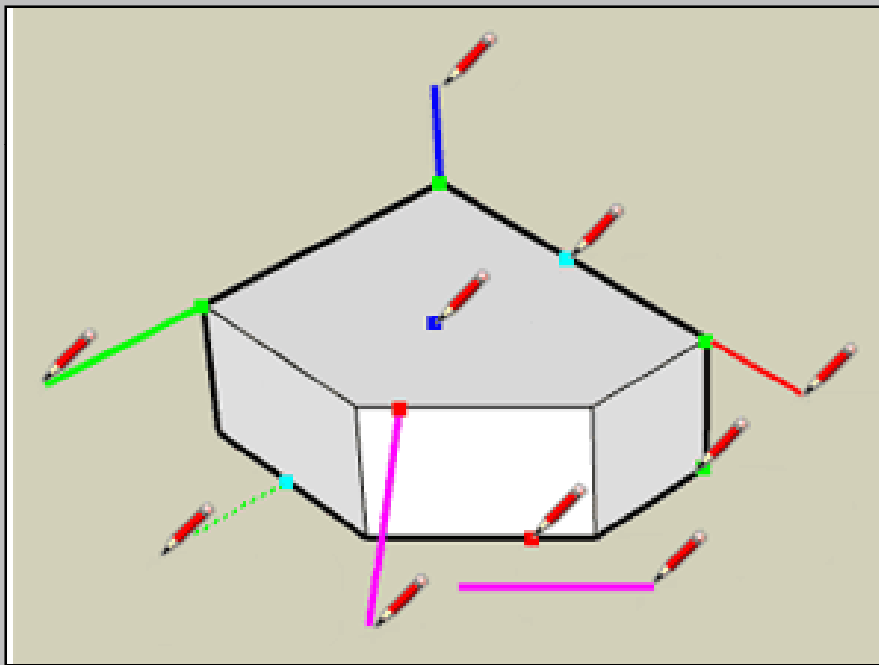

- Green dots = Endpoints
- Red dots = On an edge
- Cyan dots = Midpoints of edges
- Blue dots = On a surface
  
- Red line = X axis
- Blue line = Y axis
- Green line = Z axis
  
- Magenta line = something is parallel or perpendicular to an edge
  
- Hold SHIFT to capture and lock an inference

## Axis Coordinate System

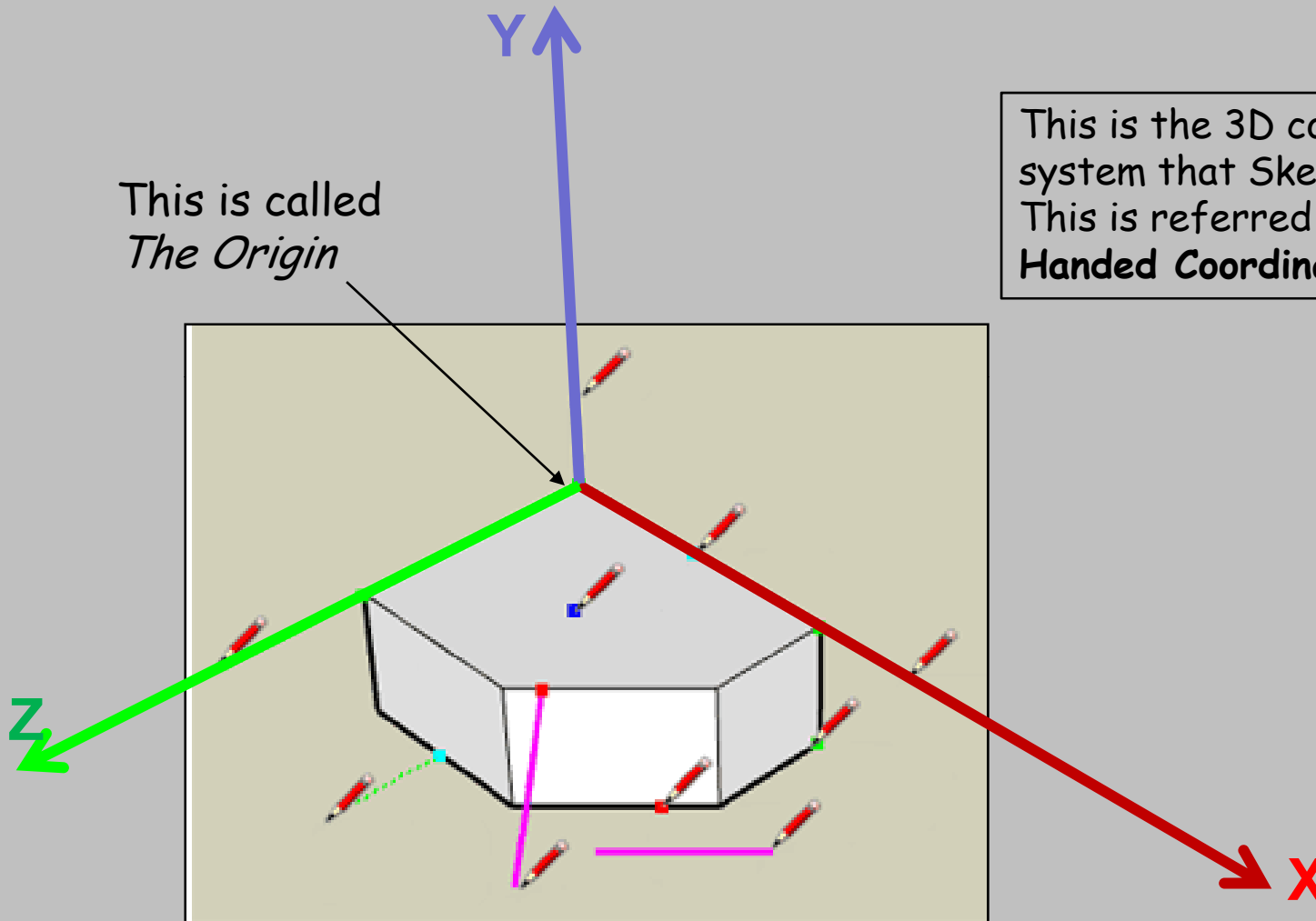

- Red line = X axis
- Blue line = Y axis
- Green line = Z axis

## Exporting an Image File

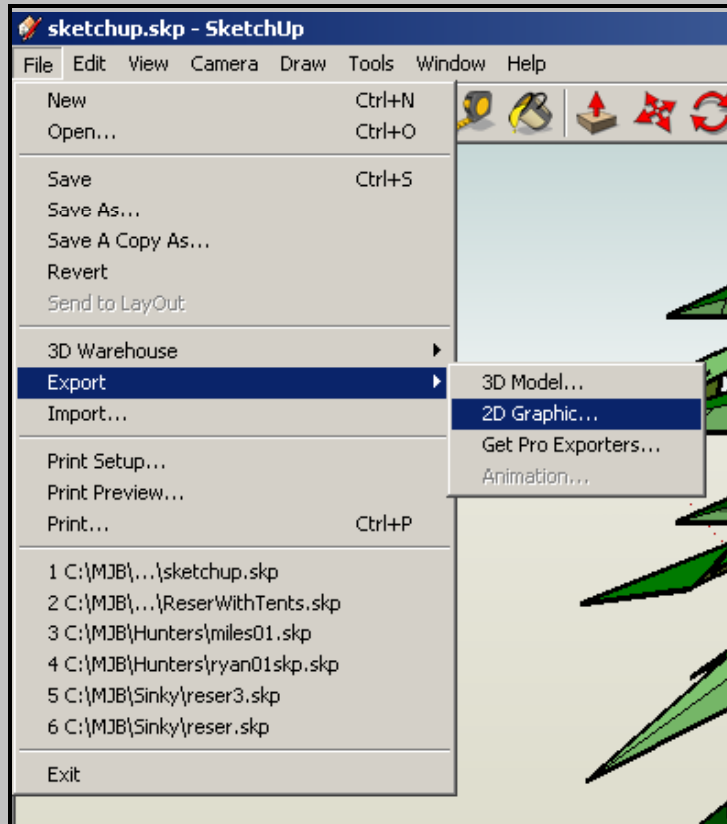

Click **File**→**Export** →**2D Graphic**

Your image can be exported in one of 4 formats:

1. **BMP**
2. **JPEG**
3. **TIF**
4. **PNG**

You would do this, for example, to email someone an image of your scene, to import it into a document, or to put it on your website

You can also export the 3D scene, but in the free version, only to Google Earth format. For more 3D formats, you need the Pro version.

# Changing the Person's Clothing

The person in the default scene is a SketchUp "Component", that is, he is a group of geometry collected together. To change his clothing, you need to first break, or "Explode", the collection apart.

Even easier, right-click on the person and select Explode from the pop-up menu.

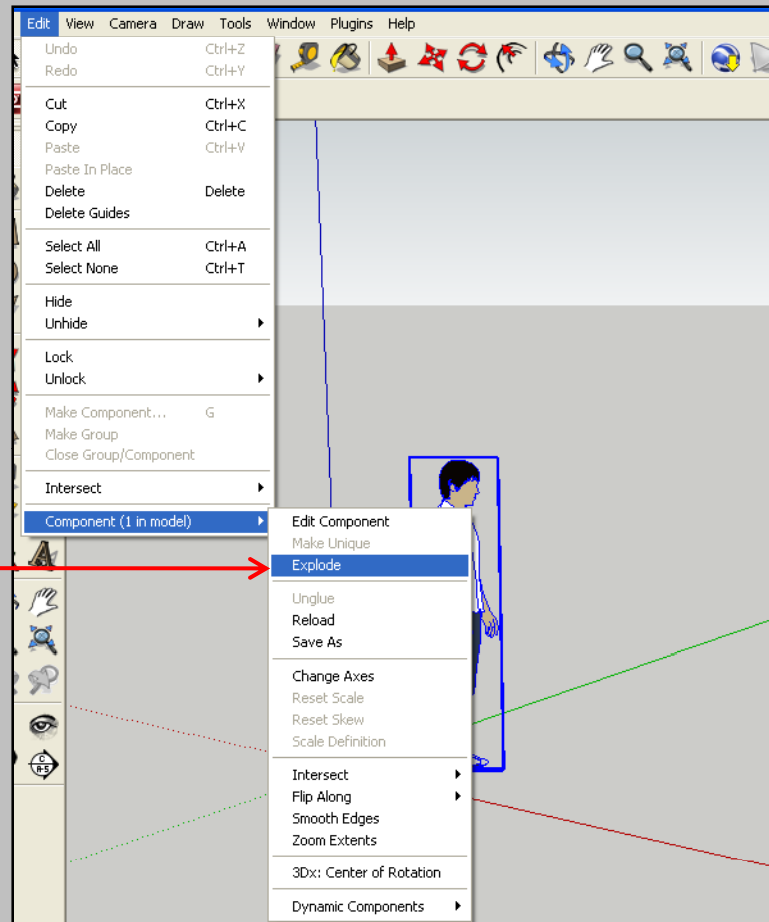

After that, you can click on **Window**→**Materials** and re-color or re-pattern the clothing

## Creating Groups

Sometimes you would like to collect several pieces of geometry together and be able to treat them as a single unit. This is called a SketchUp **Group**.

Create a SketchUp Group by first clicking on the **Select** icon.



Then, click on the first object you want in the Group. It will turn blue.

Then, hold down the **Shift** key and click on all other objects you want in the group. They will also turn blue. If you select the wrong item, just click it again to un-select it.

You can select many things at once by creating a rectangle around all of them with the Select cursor.

When you are done, right-click and select **Make Group** from the pop-up menu.

To ungroup the objects, right click on them and select **Explode** from the pop-up menu.

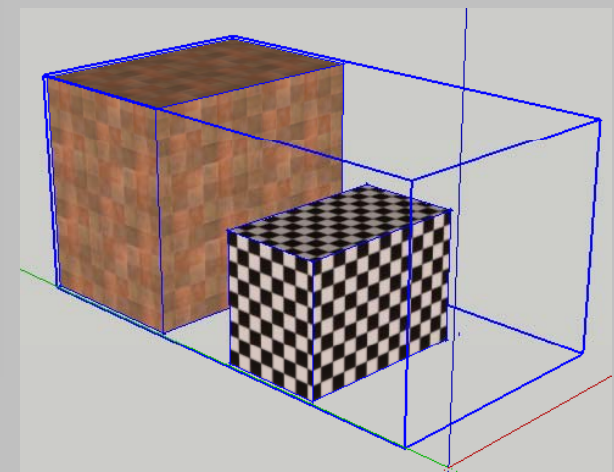

## Hiding Geometry

Sometimes it would be nice to temporarily eliminate some geometry so that you could see inside something. This is referred to as **Hiding**.

To hide one or more pieces of geometry, select all of them as if you were about to create a group.

Then, right-click and select **Hide** from the pop-up menu. The selected objects look like they are gone, but they aren't. They're just hidden.

This is useful for putting things into an object (such as furniture) or for editing the object (as is needed here).

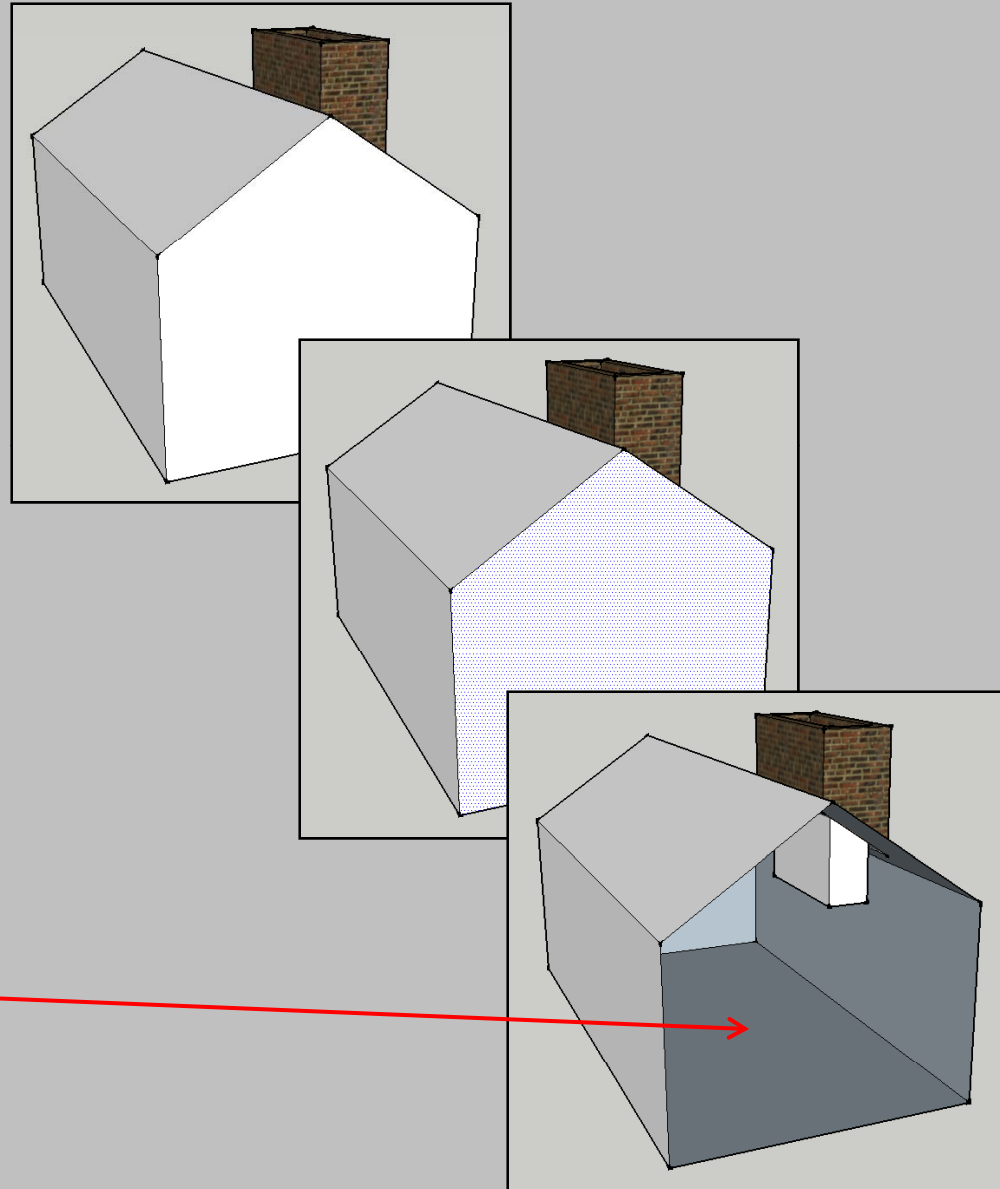

## Un-Hiding Geometry

There are two ways to bring back hidden geometry.

The first is to select **Edit**→**Unhide**→**All**, like this:

The second is to select **View**→**Hidden Geometry**. This will make hidden geometry show up like this: From there, you can right-click on it and select **Unhide** from the pop-up menu.

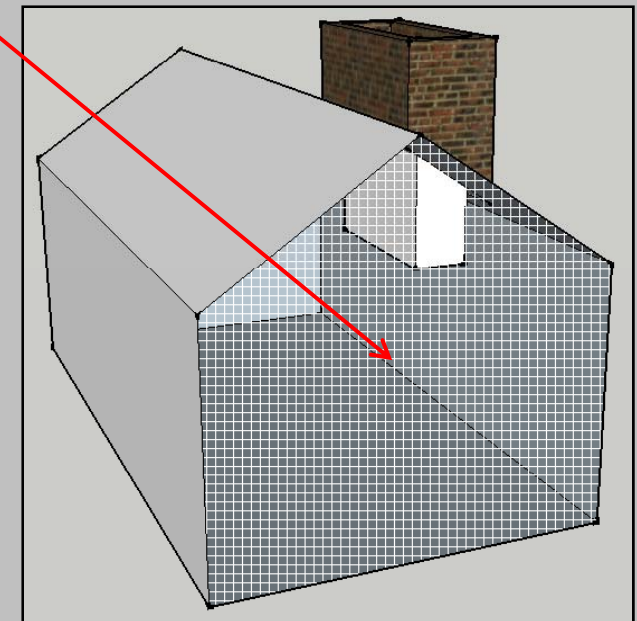
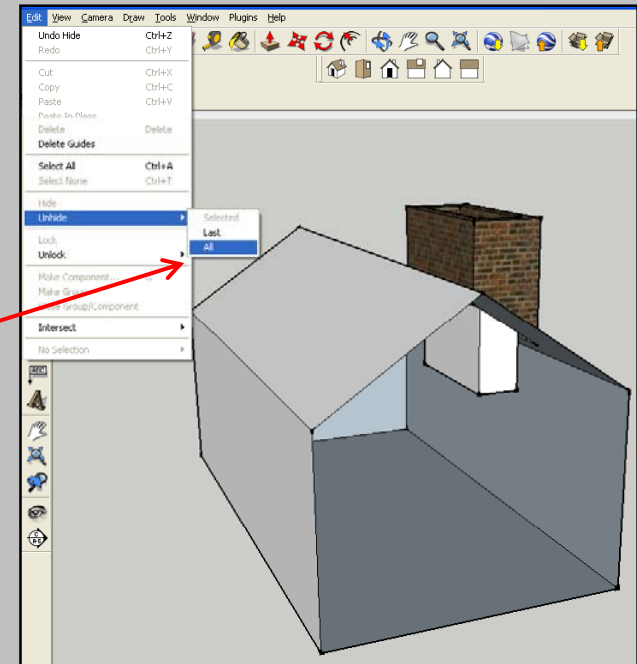

## Eliminating Geometry

Sometimes extruding geometry results in it existing in places it shouldn't.

To eliminate any geometry, take the **Eraser** tool and click on the edges of the geometry you want to eliminate.



As soon as an edge of a surface has been eliminated, the surface will disappear too.

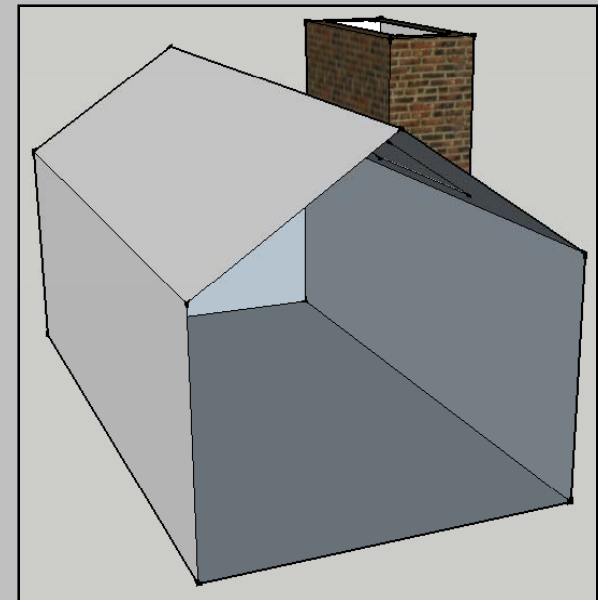
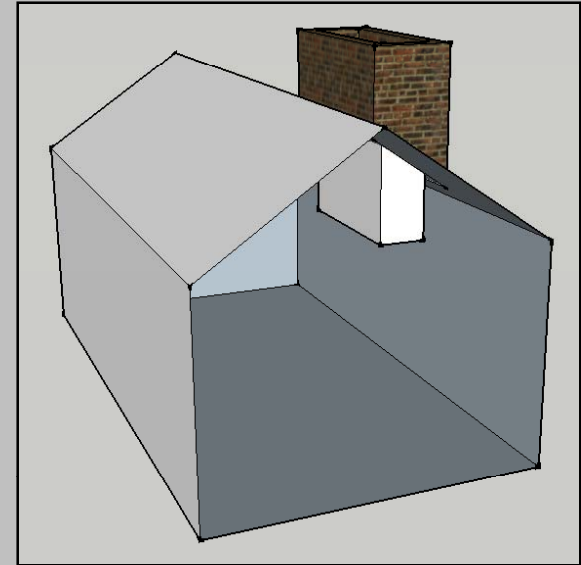

## Move Tricks



You can turn the Move into a Copy by holding down the **Control** key.

You can force the Move/Copy to move along one of the 3 axes (red, green, or blue) by holding down one of the arrow keys as follows:

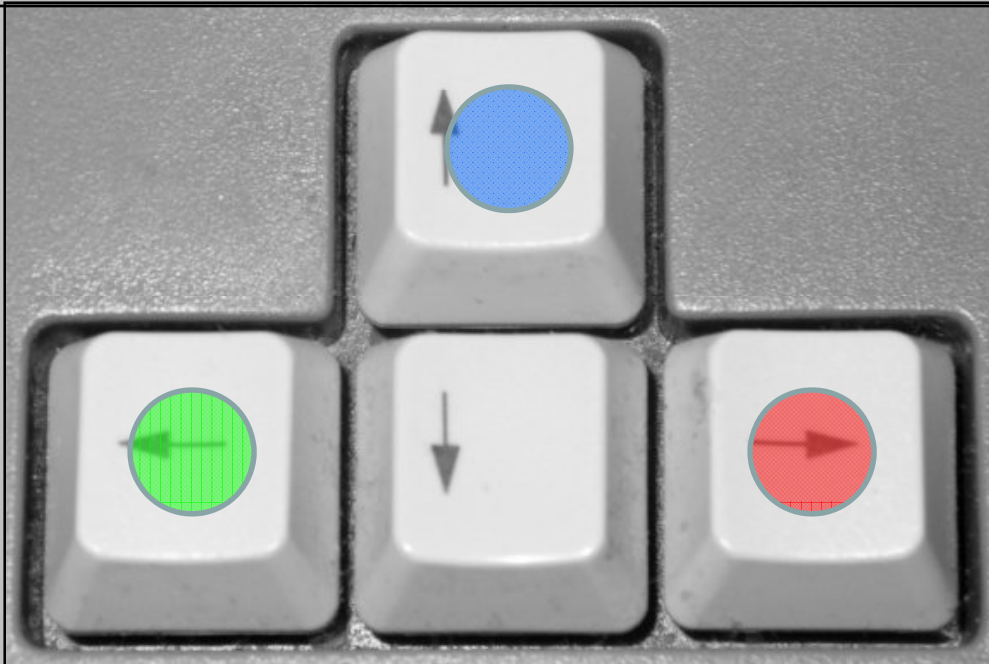

# Dimensions

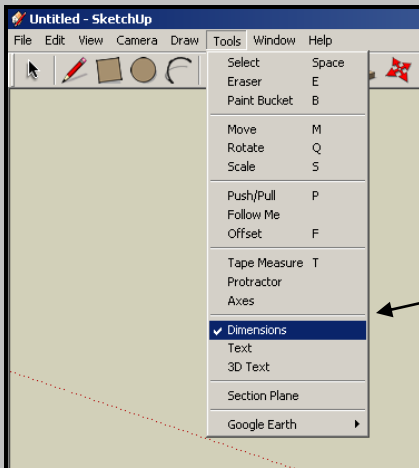

Click Tools → Dimensions

1. Click on an edge
2. Drag where you want the dimension to be drawn

1. Click on the circumference of a circle
2. Drag where you want the dimension to be drawn

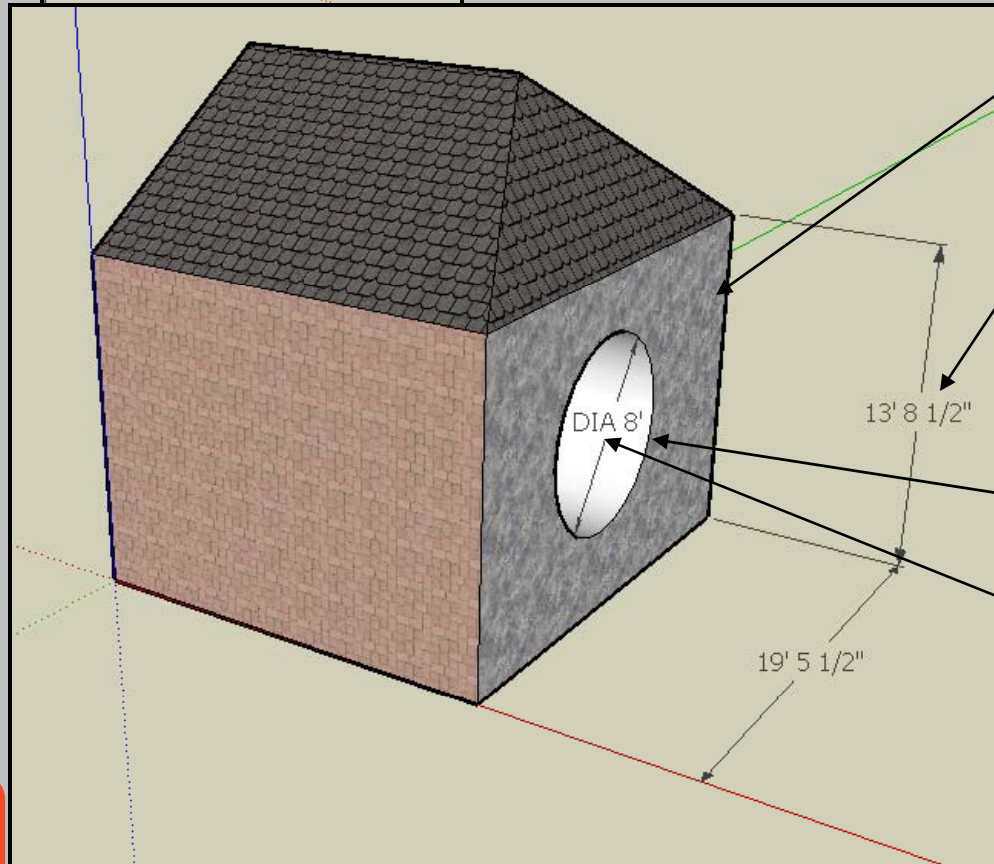

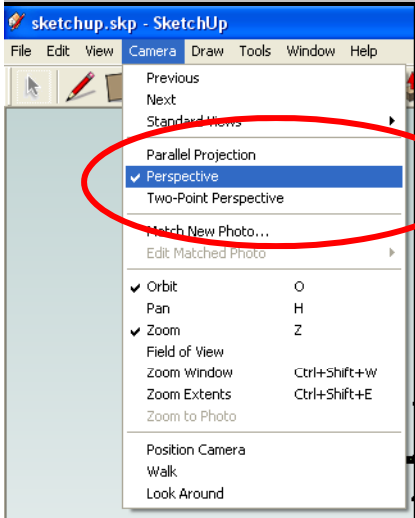

## Projections

Click **Camera**→**Perspective**

Click **Camera**→**Parallel Projection**

In perspective, things get smaller as they get farther away. In parallel, they don't. But parallel helps you see if front and back faces line up.

"Vanishing Point"

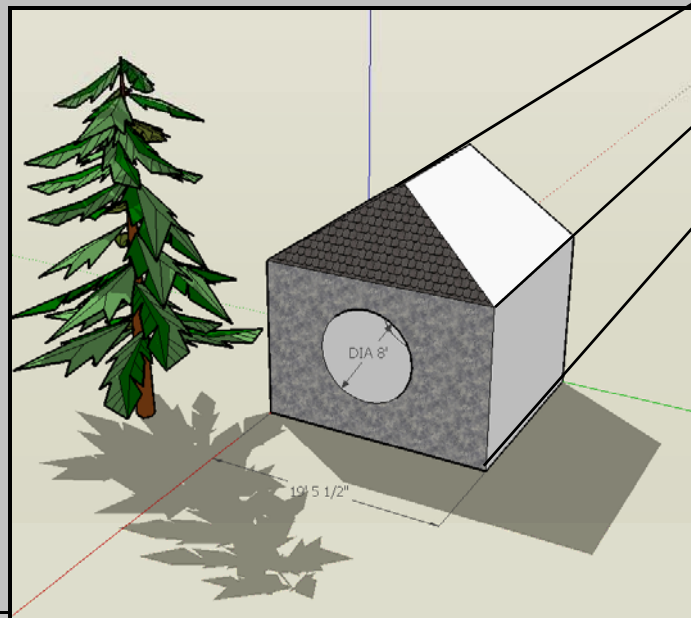

Perspective

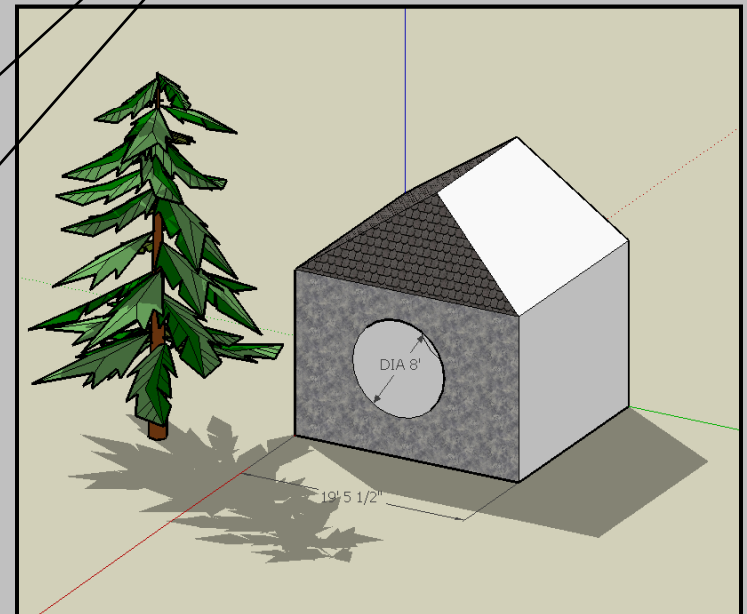

Parallel

## Drawing an Arc

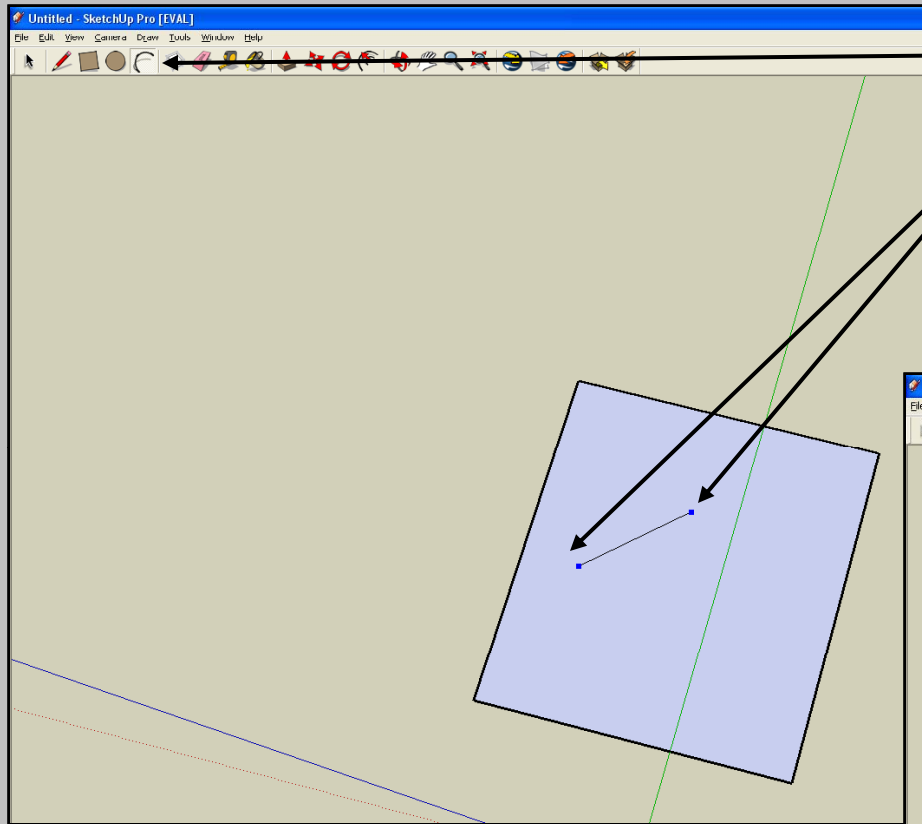

1. Click on the Arc Tool
2. Select two points for the chord
3. Select a third point that shows SketchUp where to “bulge” the arc

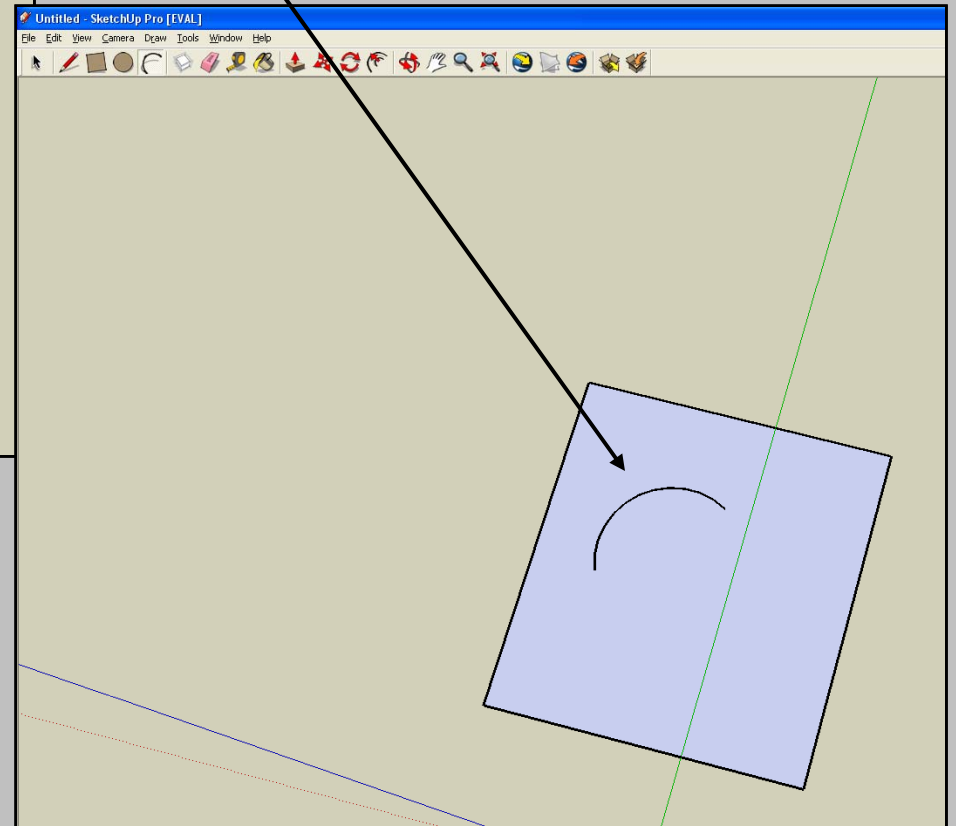

## Offsetting a Surface

1. Click on the Offset Tool 
2. Select the surface to offset on
3. Move the mouse to show how much to offset – click when ready
4. This only creates offset edges – you need to use the Push-Pull Tool to do something with it.

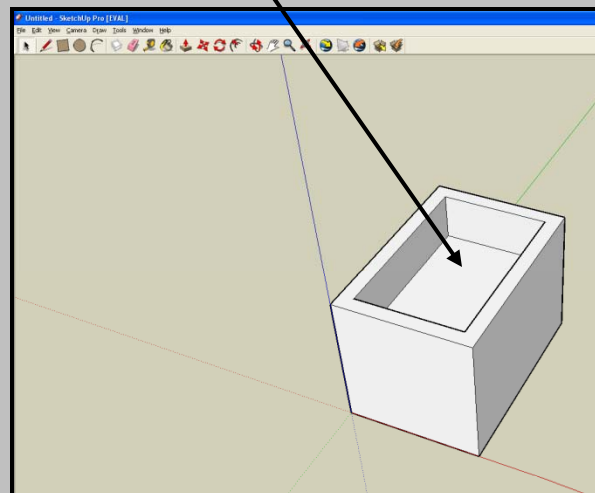
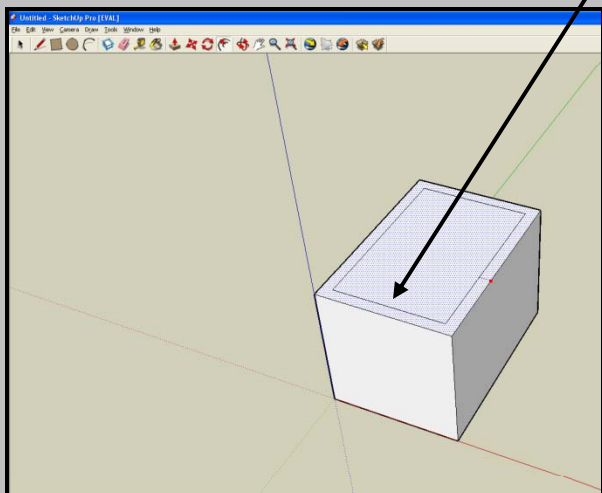
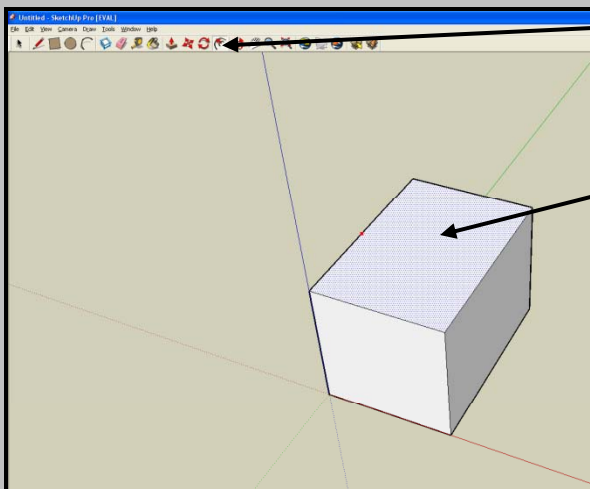

## Making a Swimming Pool: Arcs and Offset Surface Edges

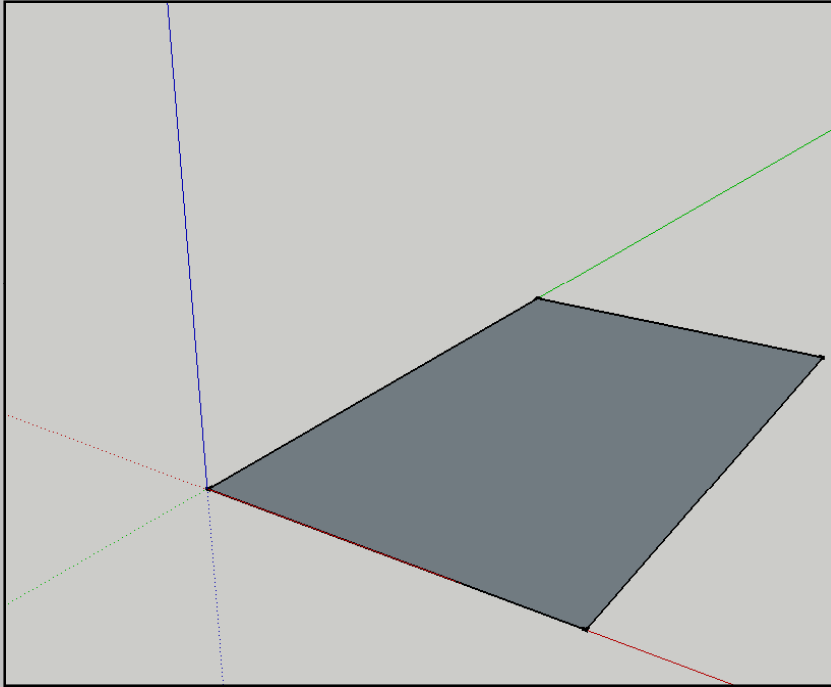

1. Create a rectangle on the floor

## Create an Arc in each Corner to Round the Corners

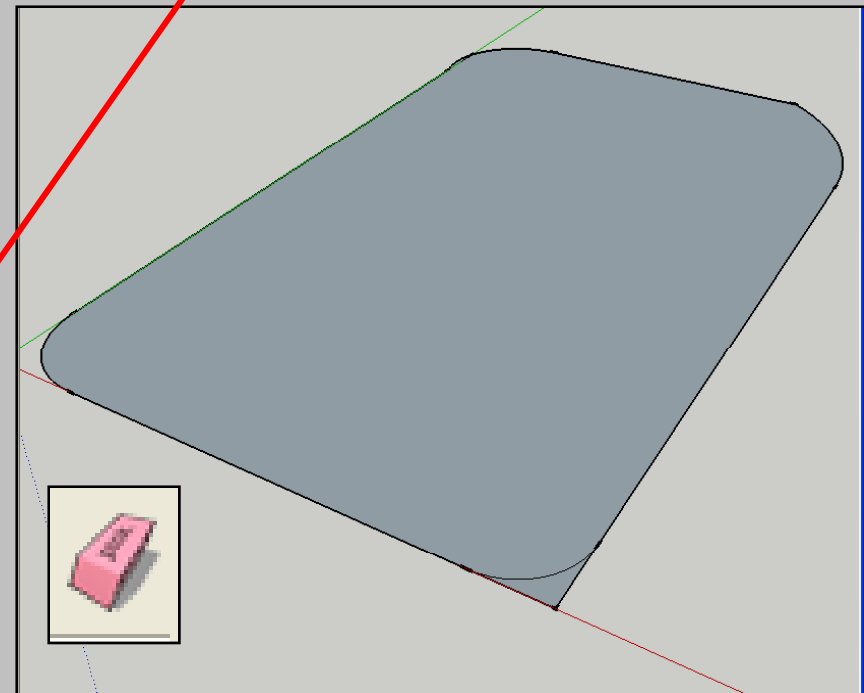
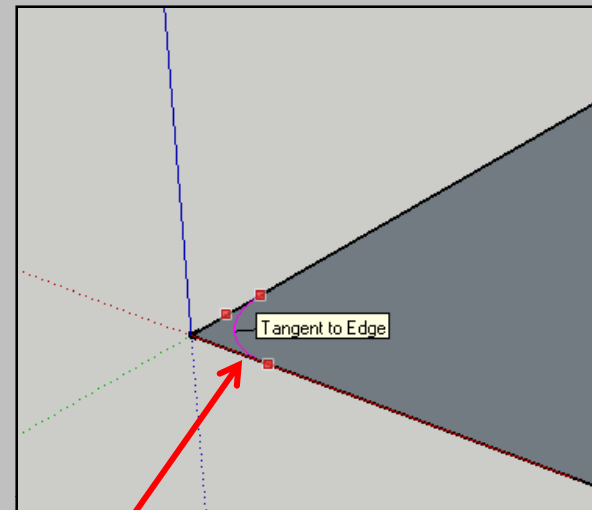
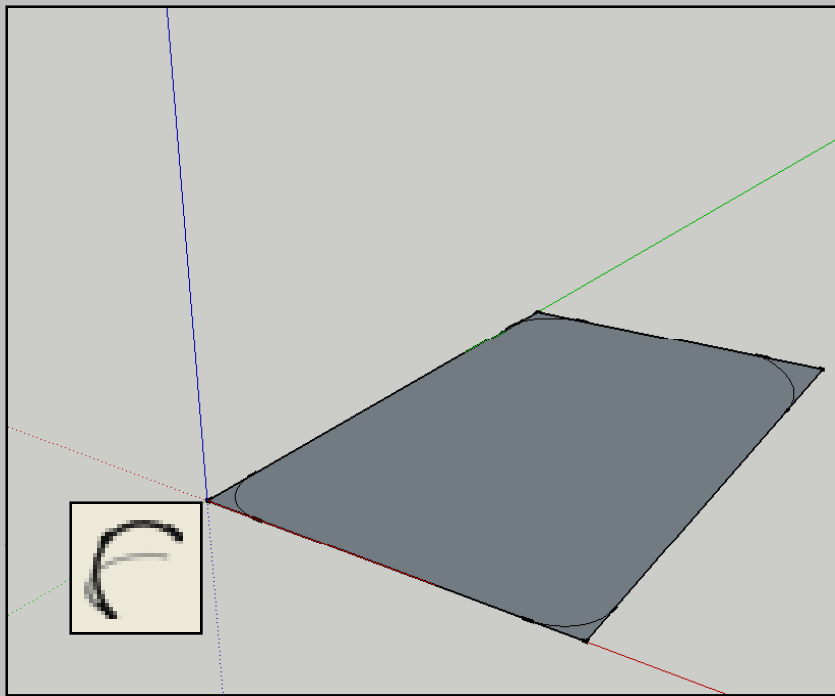

2. Use the Arc Tool
3. Click on one edge, then click on the adjacent edge
4. The third point will define where the arc goes through. Mouse around until SketchUp tells you that the arc is now tangent to the edge
5. When you're done with the four corners, use the Eraser Tool to erase the old sharp corners

## 6. Use the Push/Pull Tool to Lift it into 3D

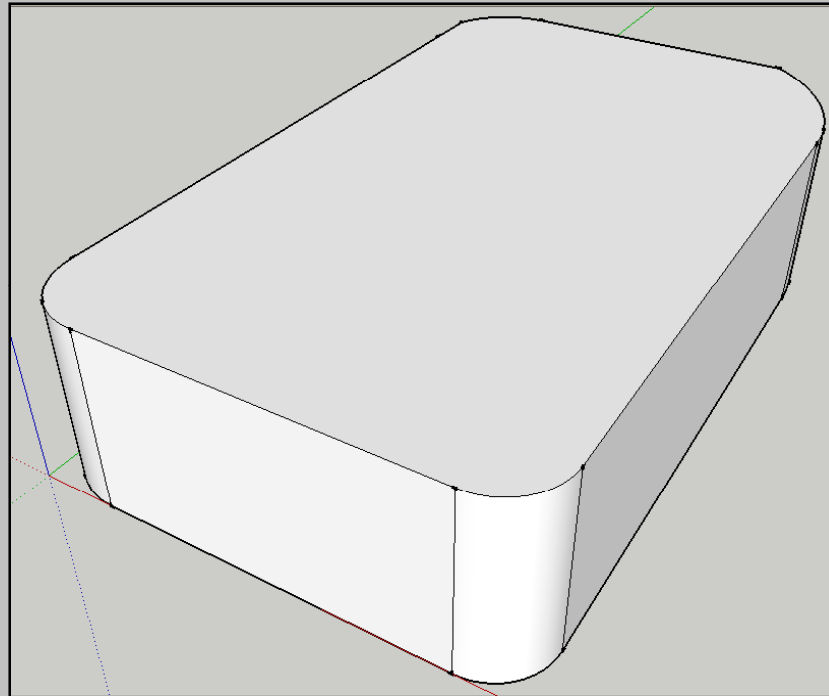

7. Use the Offset Tool to create an Inner Edge, then
8. Use the Push/Pull Tool to Push it Down

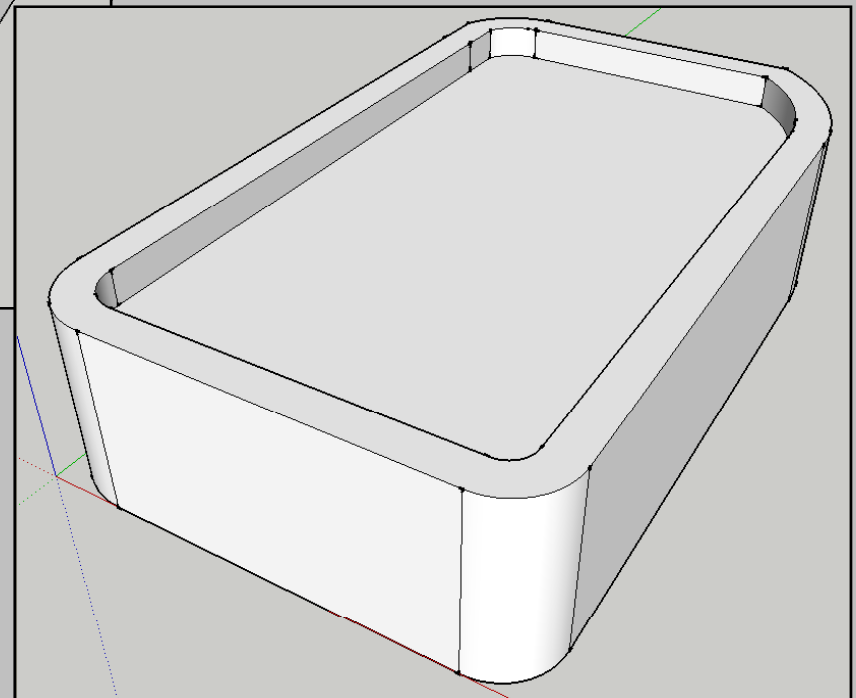
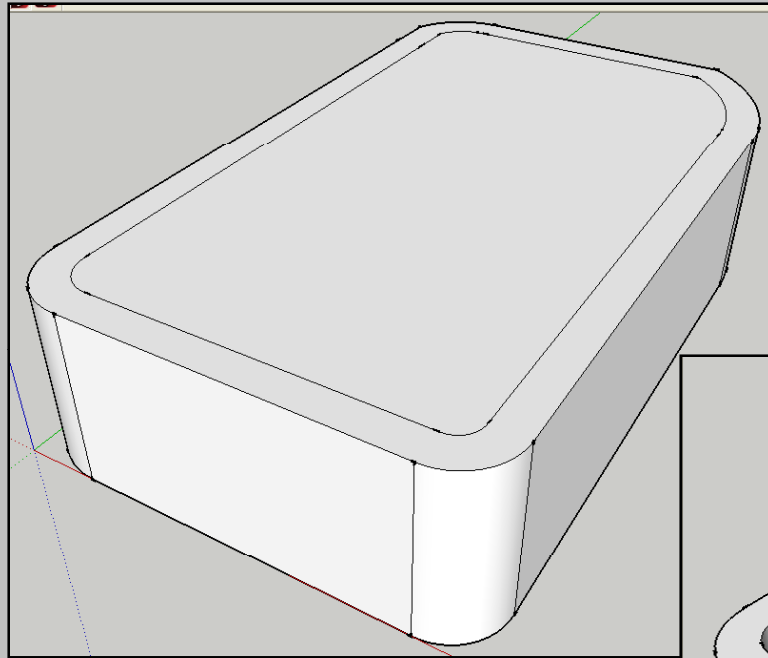
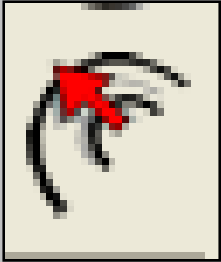

## 9. Use the Window → Materials Dialog Box to Add Tile and Water

If you hold down the Control Key when adding the tile pattern, it will apply it to all surfaces, not just one. This saves you a lot of time.

Then add the water pattern after that.

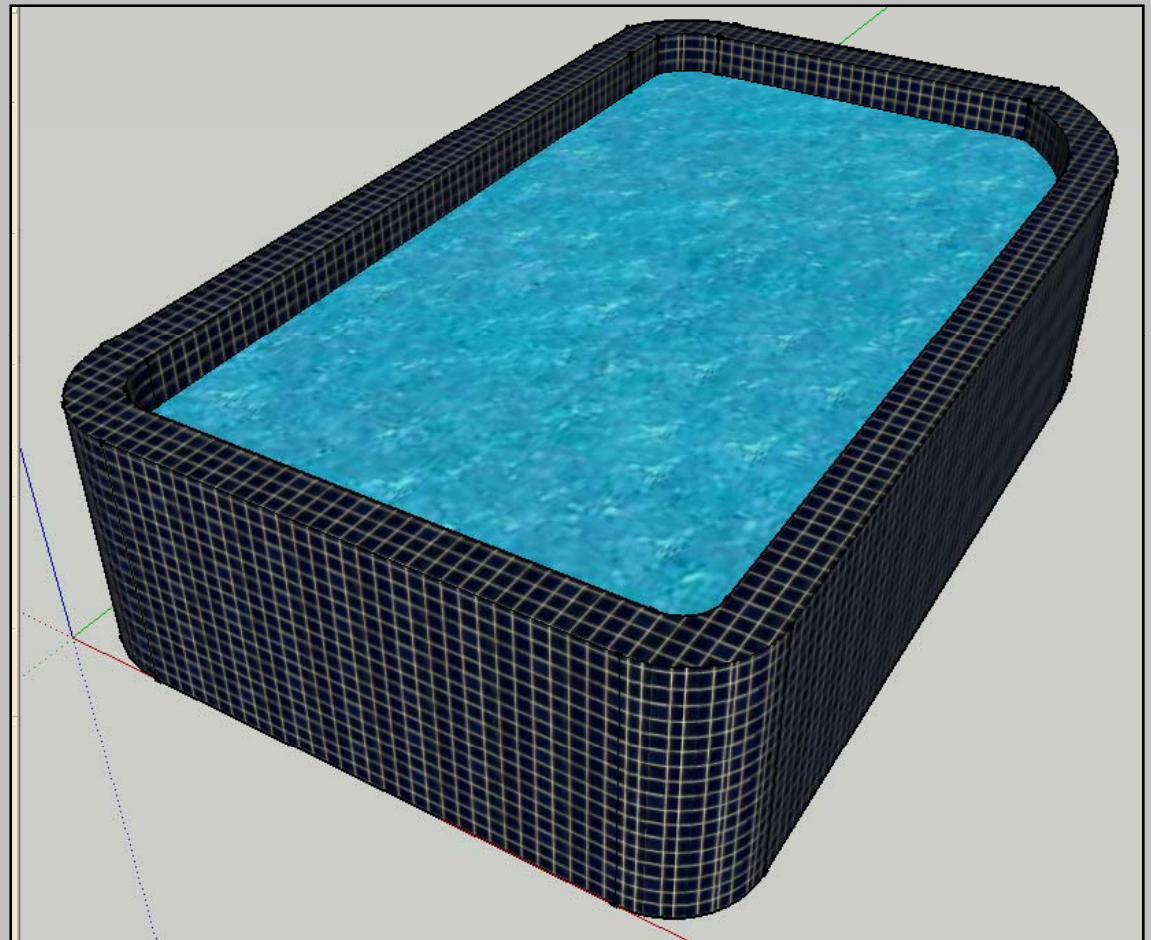

## Adding Fog

This brings up the Fog dialog box

Click **Window**→**Fog**

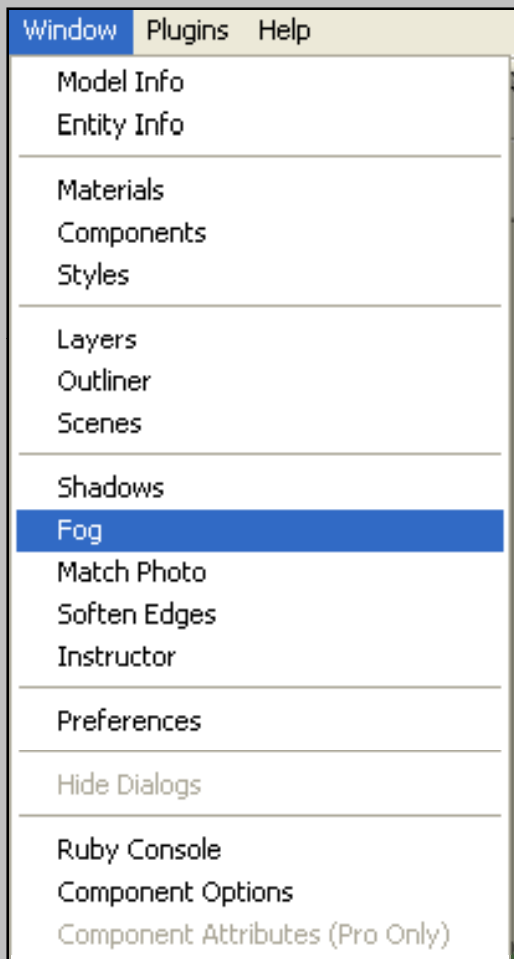

Click here to turn the fog feature on

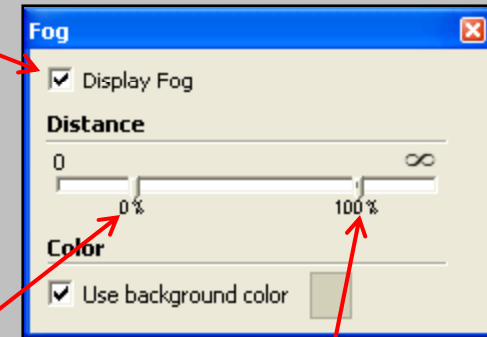

This slider adjusts how far in front of your eye the fog starts. Items closer to you than this will not be fogged at all.

This slider adjusts how far in front of your eye the fog completely hides your scene. Items farther away than this will not be visible at all.

# Adding Fog



## Adding 3D Text

1. Click on **Tools**→**3D Text**
2. Type the text into the dialog box
3. Make any text settings you want
4. Place the text by clicking on an object

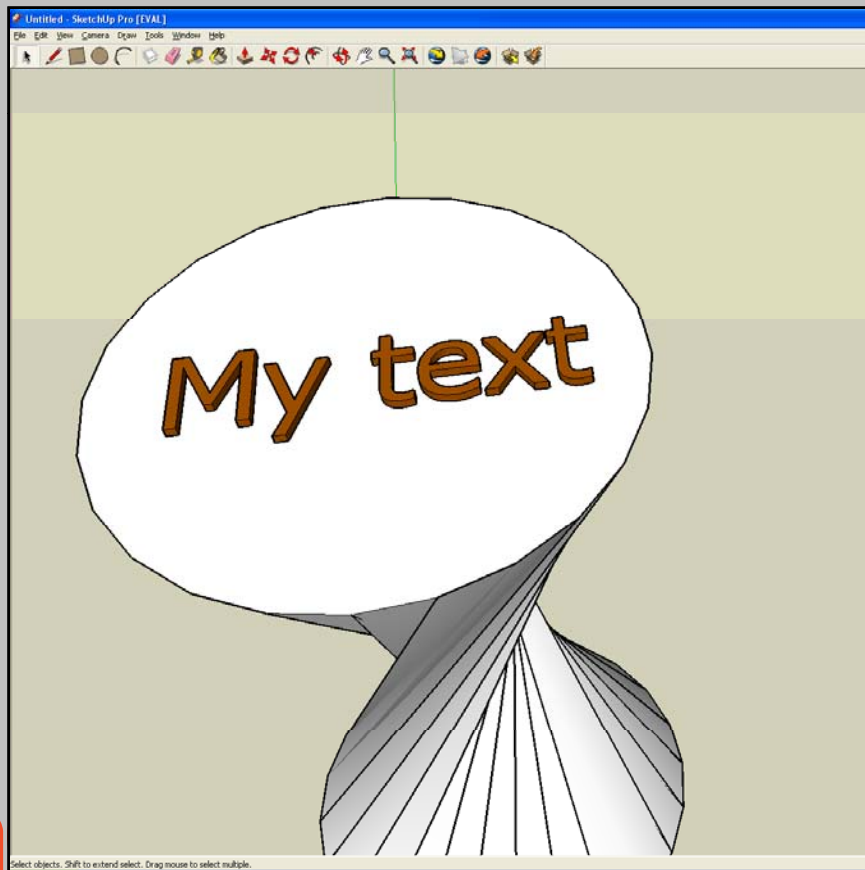

## Rotating an Object

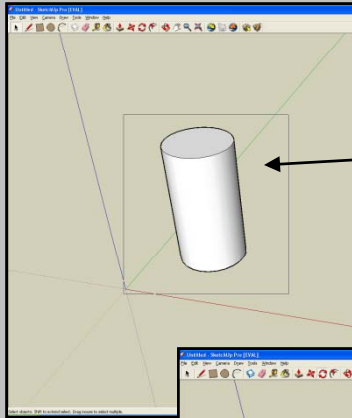

1. Select the entire object

2. Click on the **Rotate Tool**

3. Click the Protractor onto the object

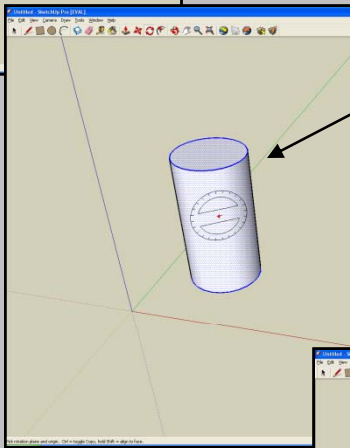

4. Rotate the Protractor with the mouse to align it with something (e.g., a key point) -- click when ready.

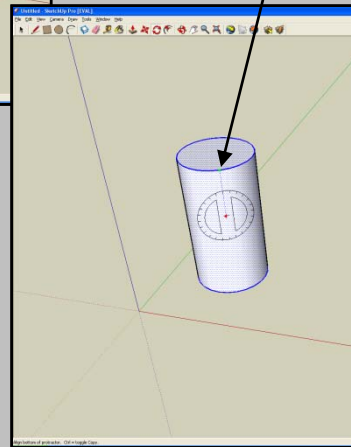

5. Rotate the object. Click when done.

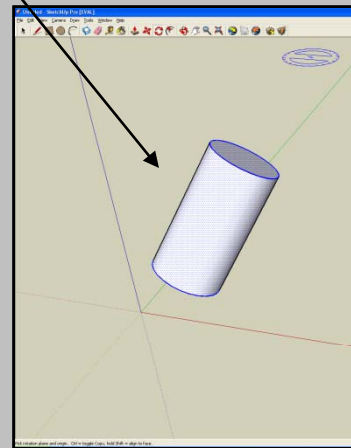

## Rotating a Face

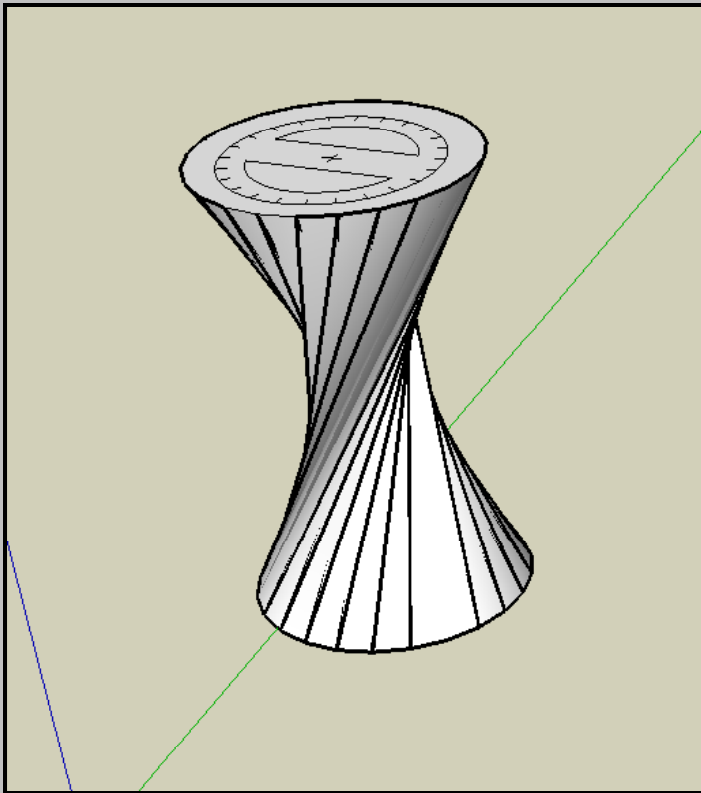

Strange as it may seem, you can also rotate just a face. Follow the same procedure, but select only the face.

## Scaling an Object

1. Select an object
2. Select **Tools**→**Scale**
3. Move the grips with the mouse
4. Hold down the **Control** key if you want scaling about the object's center

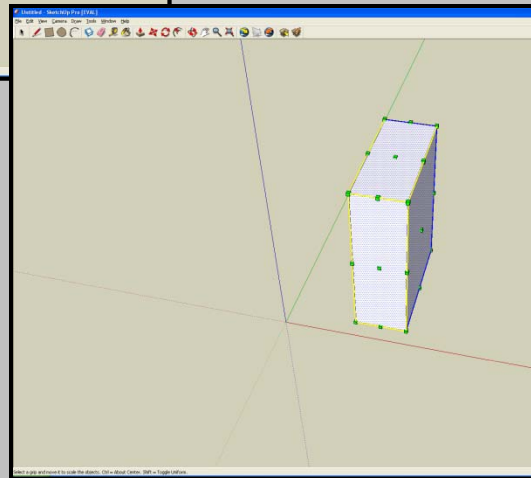
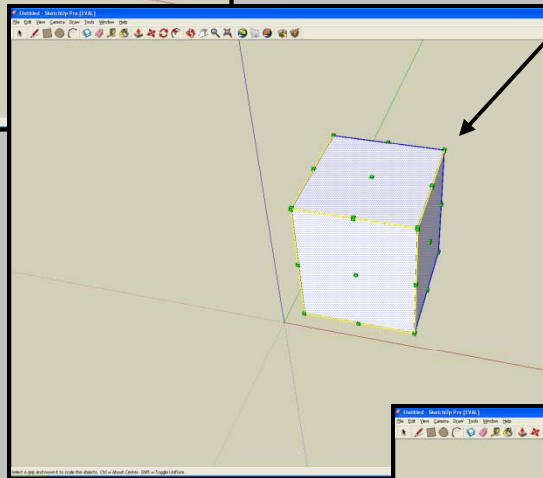
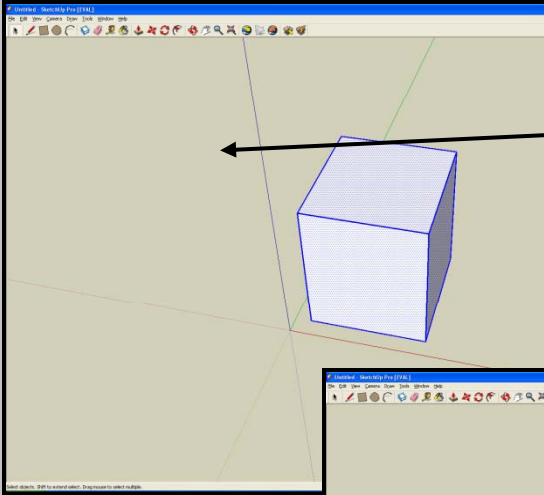

## You can also scale just a face

1. Select a face
2. Select **Tools**→**Scale**
3. Move the grips with the mouse
4. Hold down the **Control key** if you want scaling about the object's center

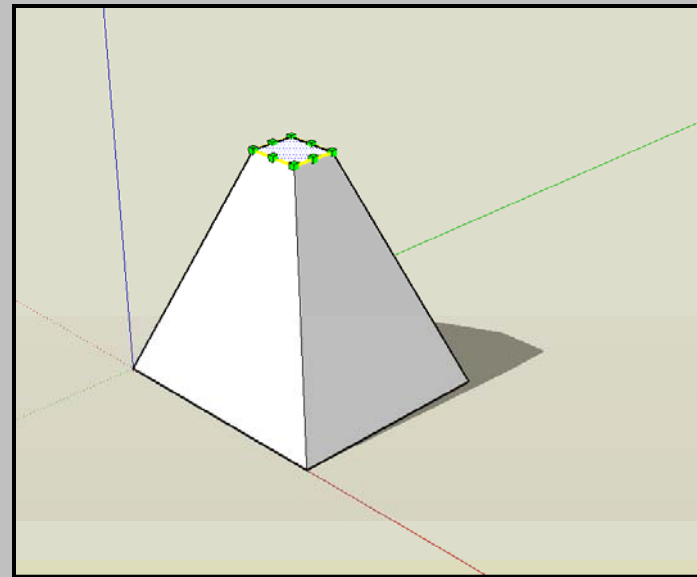
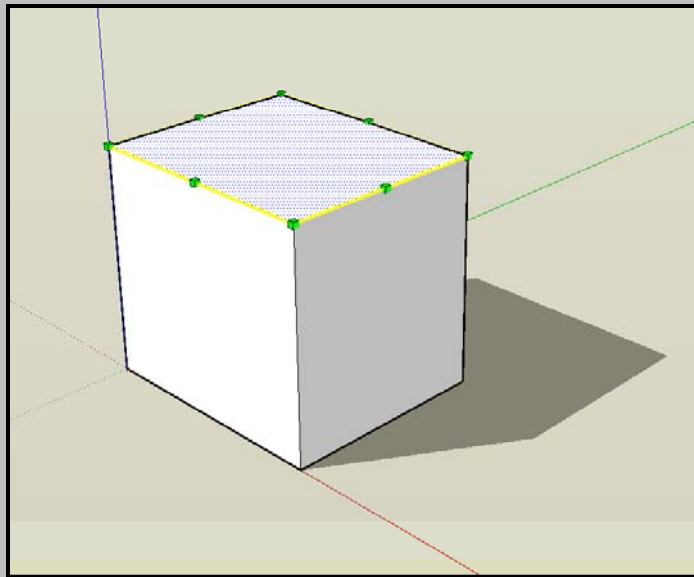

## Sectioning an Object

1. Select an object
2. Select **Tools**→**Section Plane**
3. Select the section plane
4. Use the **Move Tool** to slide it into the object

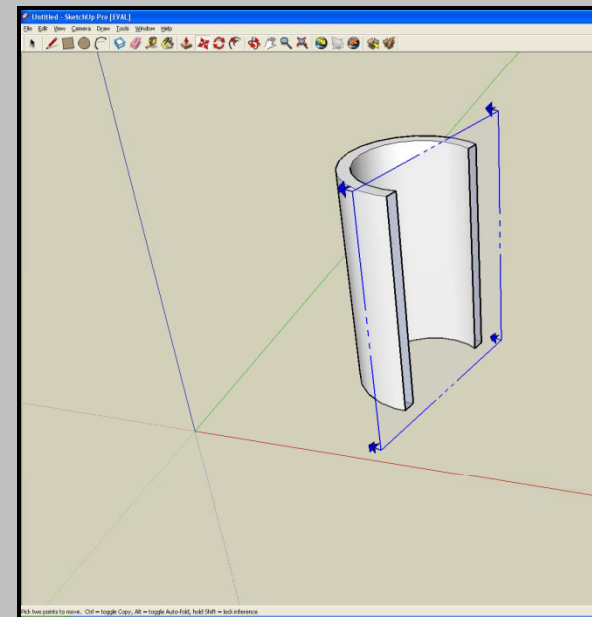
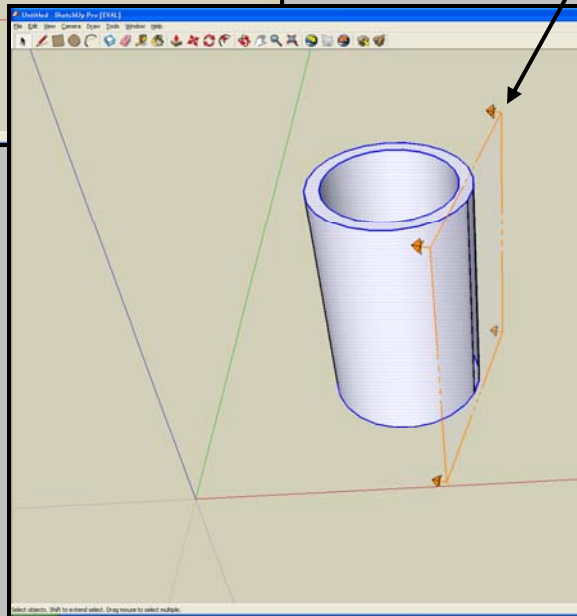
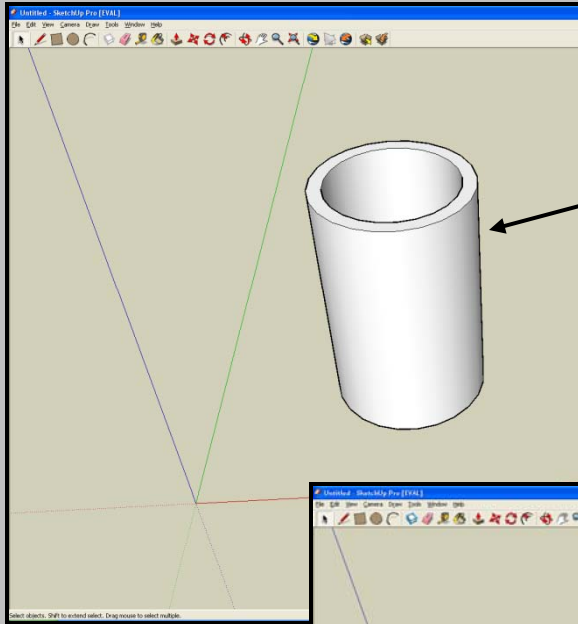

## Want to create Crown Molding?

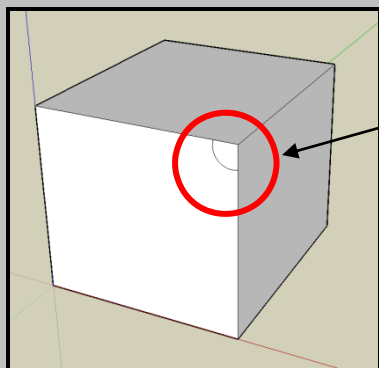

Draw an arc in the corner

Click **Tools** → **Follow Me**

Click on the arc area

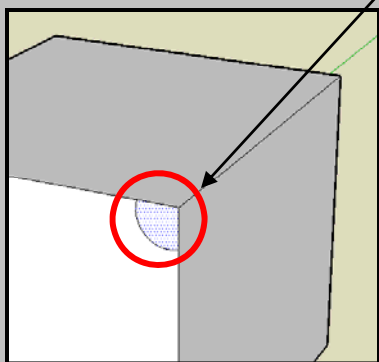

Move the cursor along the perimeter – don't click again until you are done with the full path

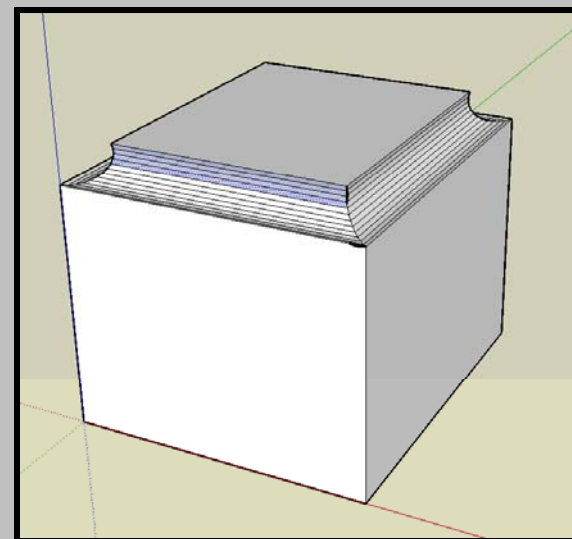
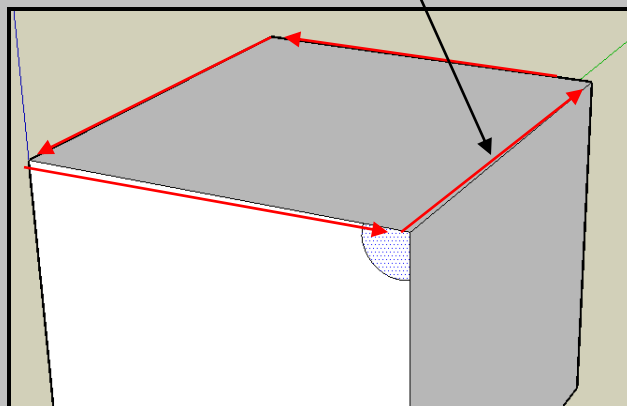

## Subtracting one Surface from Another

1. Create two objects
2. Use the **Move Tool** to overlap them
3. Select both objects
4. Select **Edit**→**Intersect**→**Intersect with Model**
5. Erase the surfaces and lines you don't need

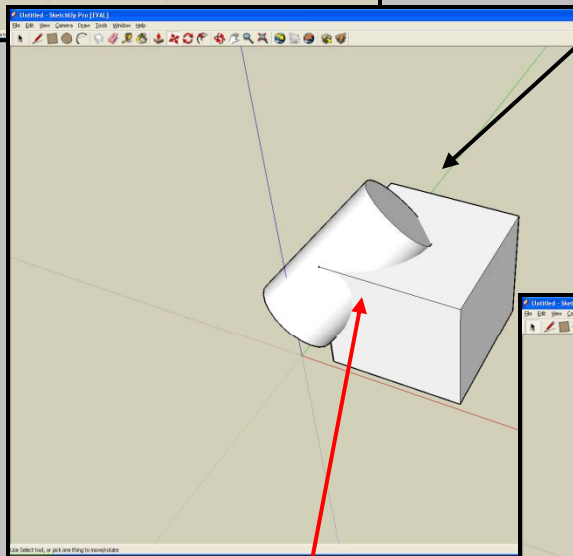
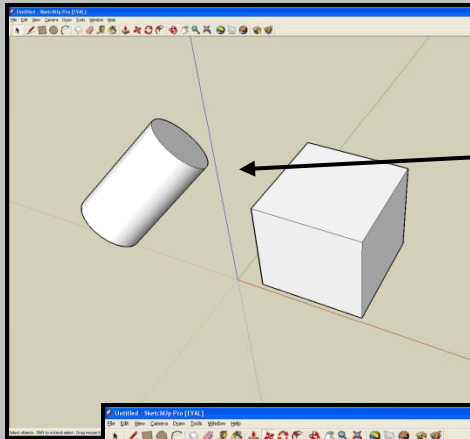

Note the difference  
in edges

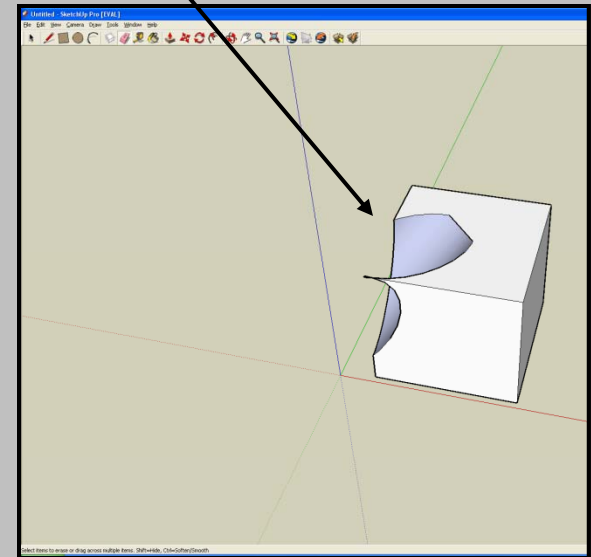
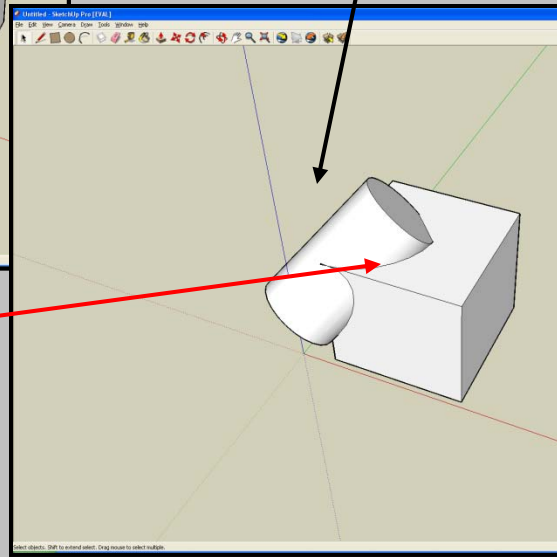

## Adding a Vertical Chimney to a Sloped Roof



1. Draw a line along the roof using the pencil tool. SketchUp's inference engine will try to force it to be parallel to an axis. Let it do that.

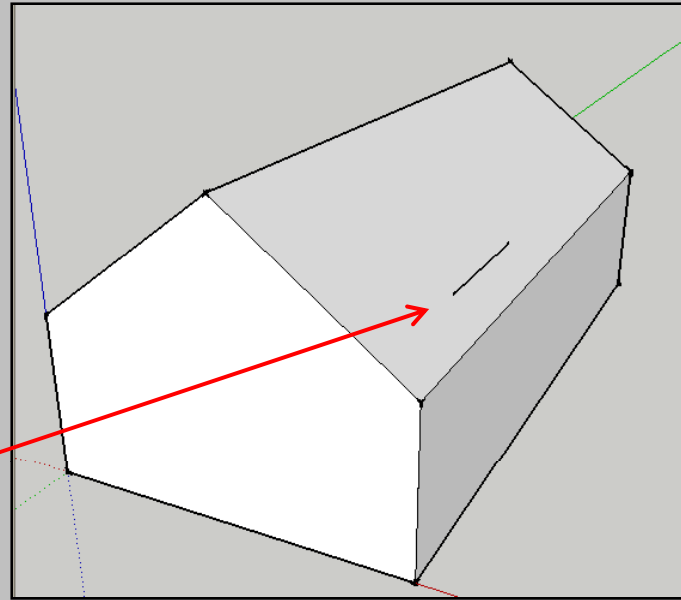

2. Select the line you just drew. Use the Move/Copy icon with the Control Key held down to lift it up in the air. (The Control key will force it to do a Copy.) Wiggle it a little bit until you get the phrase "On Blue Axis" to appear. This indicates that you are lifting it straight up.

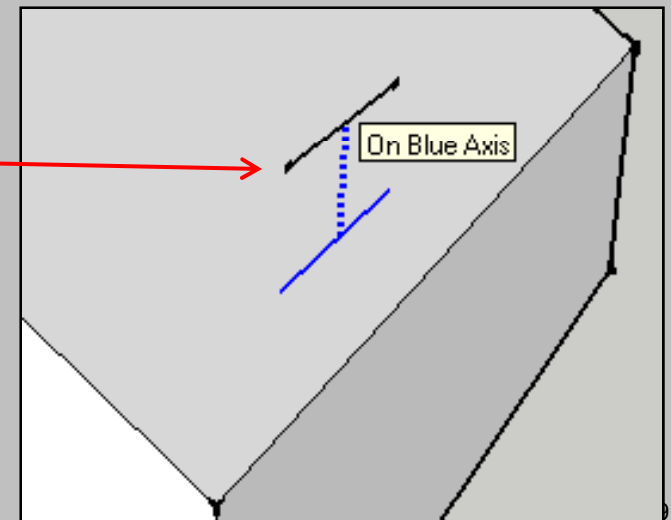

## Adding a Vertical Chimney to a Sloped Roof



3. Draw lines using the pencil tool from the ends of this new line to the face of the roof. SketchUp will tell you when you are there. Be sure the line is a color (red in this case) to indicate that you are parallel to an axis.

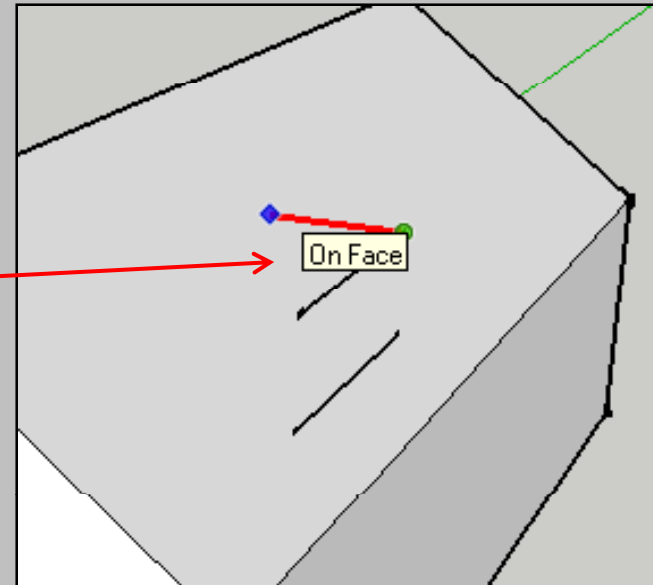

4. Using the pencil tool, connect up all the points to form edges. You should have 9 lines in all. (Don't forget to look at the back of the chimney.) SketchUp will turn the edges into faces as you complete them. There should be 4 faces in all.

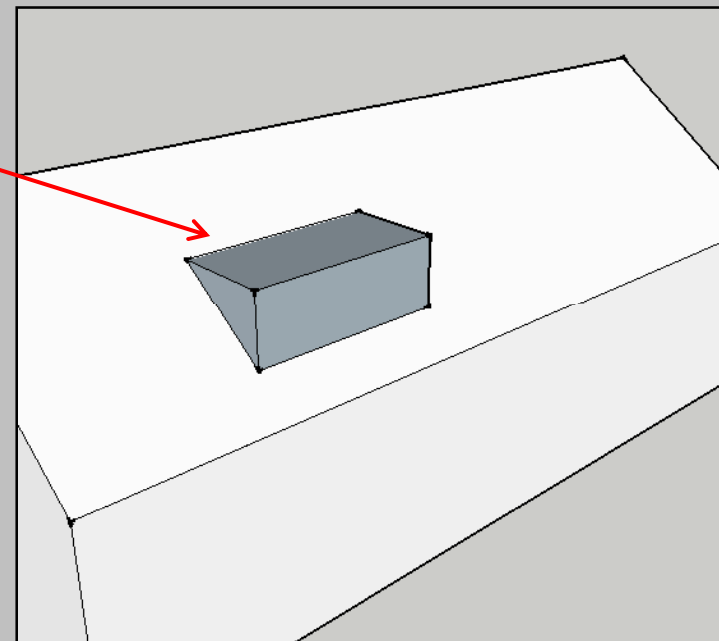

## Adding a Vertical Chimney to a Sloped Roof



5. Use the Push/Pull tool to lift the top surface.

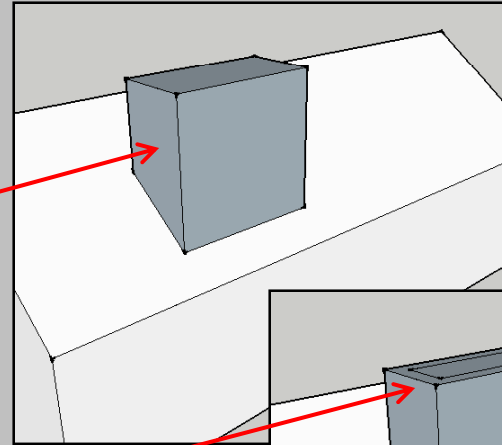

6. Use the Offset tool to make an inner surface on that top surface.

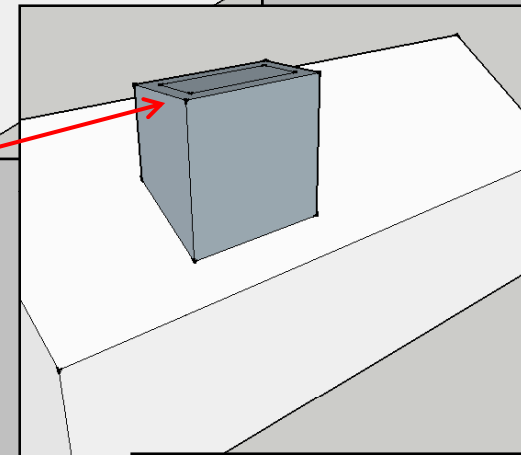

7. Use the Push/Pull tool to push that inner surface down.

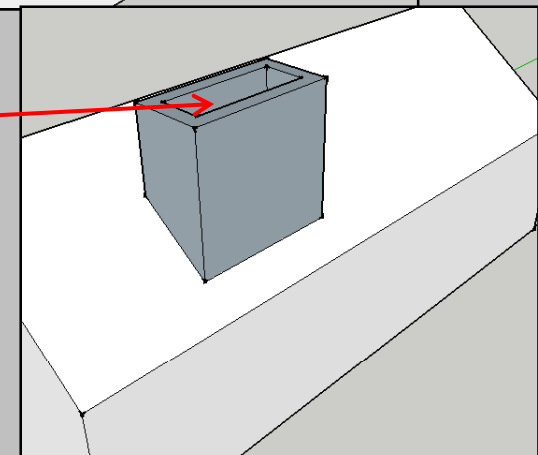

## Adding a Vertical Chimney to a Sloped Roof

8. Add whatever **Window**→**Material** decoration you want
9. Get rid of the excess chimney under the roof by hiding an end face and erasing those edges. (See previous sections.)
10. Unhide the end face when you are done

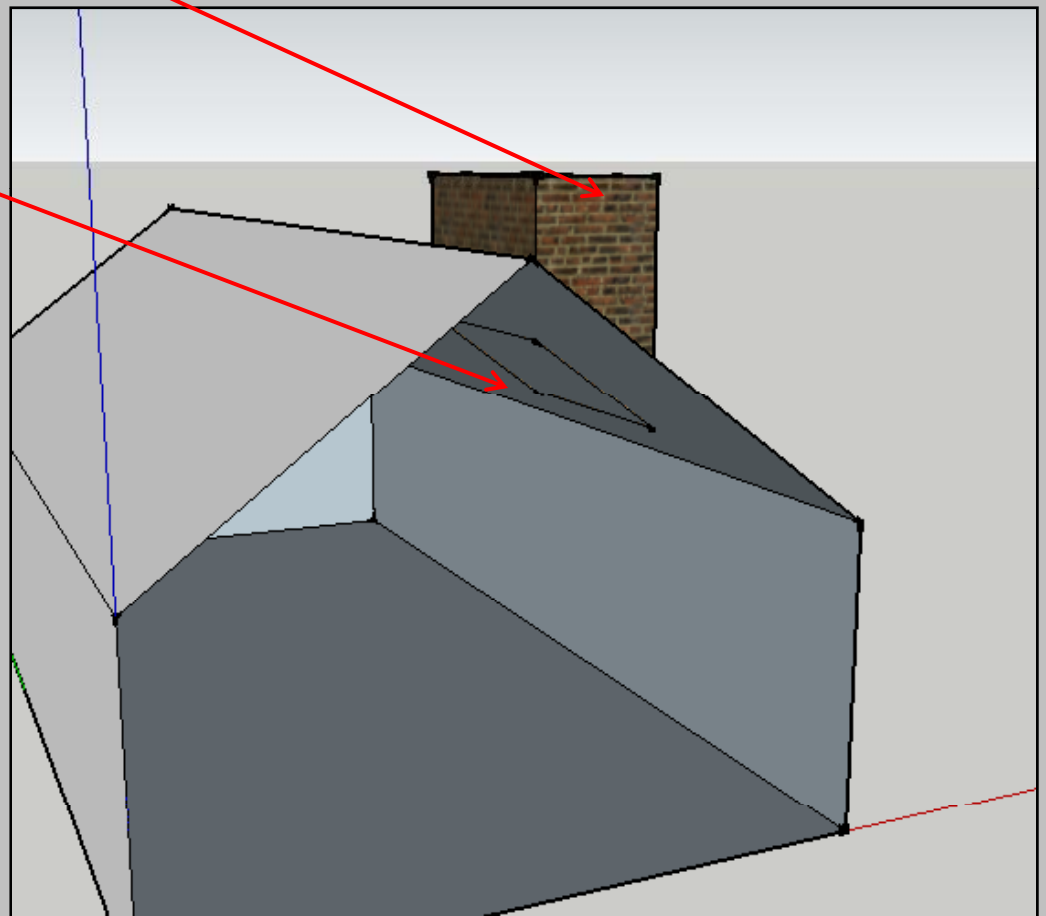

## Creating a Flying Animation

### To create an animation:

1. Create a view of the scene
2. Select **View**→**Animation**→**Add Scene**
3. Create a different view
4. Select **View**→**Animation**→**Add Scene**
5. . . .

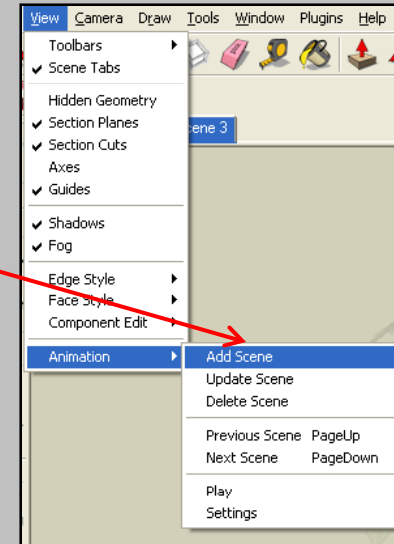

### To play the full animation:

1. Select **View**→**Animation**→**Play**
2. Pause or stop the scene with these buttons



As you add scenes, SketchUp will list them. You can click on any of them to get back to that view.



# Animation Settings

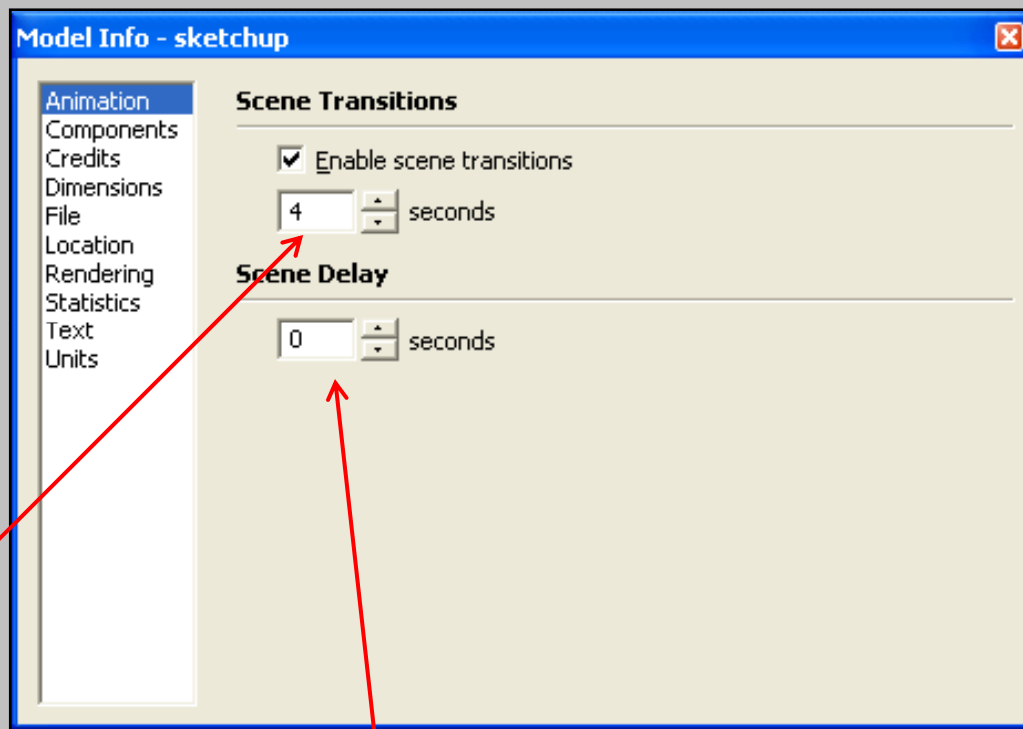
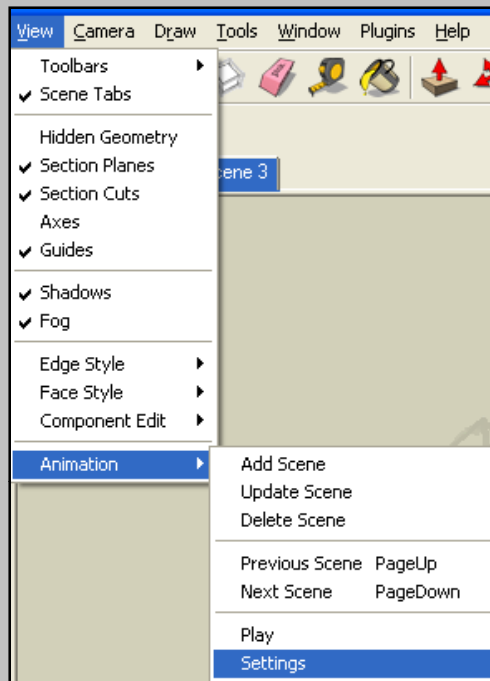

Set how long each scene transition lasts

How long to wait before starting the animation

## Exporting Your Animation

To save an animation to a file:

1. Select **File**→**Export**→**Animation**
2. Save as an AVI file

To play the animation file:

Double-click on your AVI file

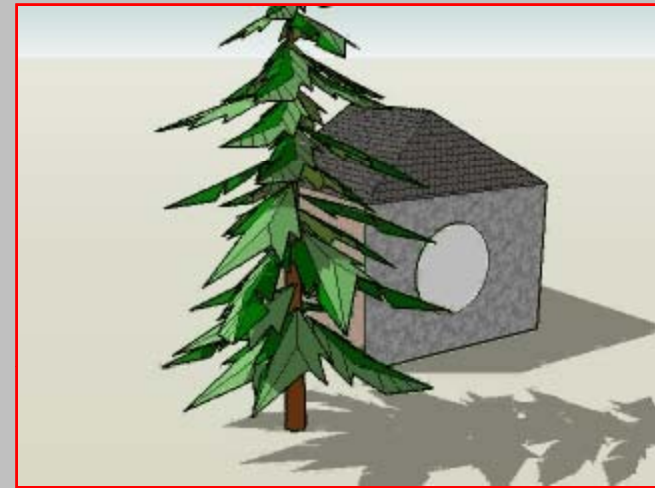

To import your animation into PowerPoint:

1. Select **Insert**→**Movie**→**Movie from File**
2. Double-click on the image when editing the slide
3. Click on the image in Slide Show mode

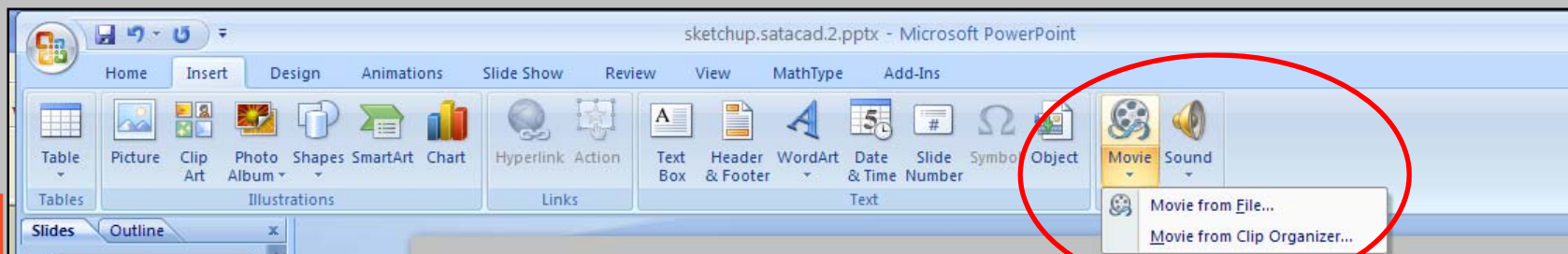

## Good SketchUp Web Links

### These Notes

<http://cs.oregonstate.edu/~mjb/sketchup>

### General SketchUp Site

<http://sketchup.google.com>

### Download SketchUp Models

<http://sketchup.google.com/3dwarehouse>

### Tips and Tricks

<http://sketchupdate.blogspot.com/search/label/Tips%20and%20Tricks>

### SketchUp Blogs

<http://sketchupdate.blogspot.com>

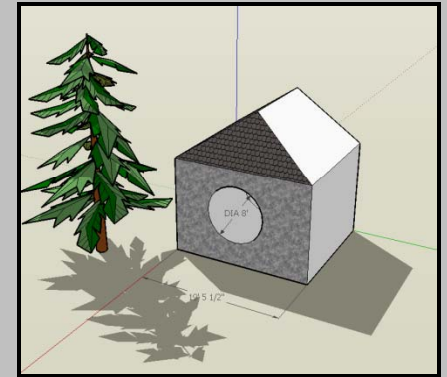

## More Good SketchUp Web Links

### Video Tutorials

<http://sites.google.com/site/3dbasecamp2008>

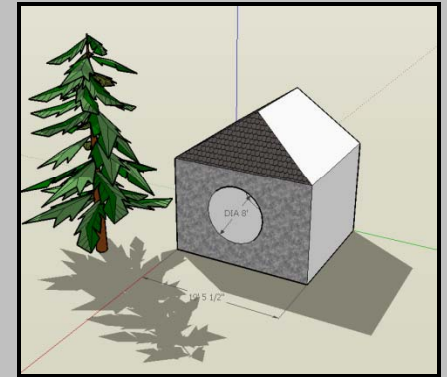

### Developing Plug-ins (Advanced!)

<http://groups.google.com/group/SketchUp-Plugins-Dev/web/index.html>

<http://groups.google.com/group/SketchUp-Plugins-Dev>

## Reference Books

Bonnie Roskes and Bob de Witt, *The SketchUp Book*.

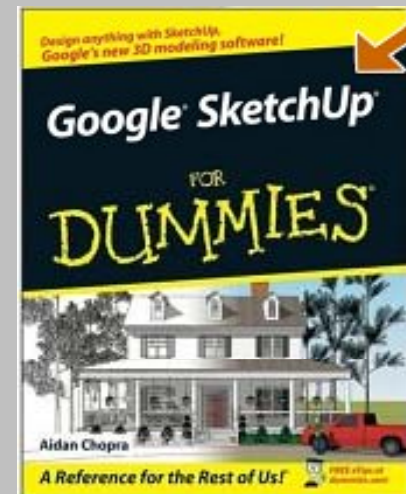
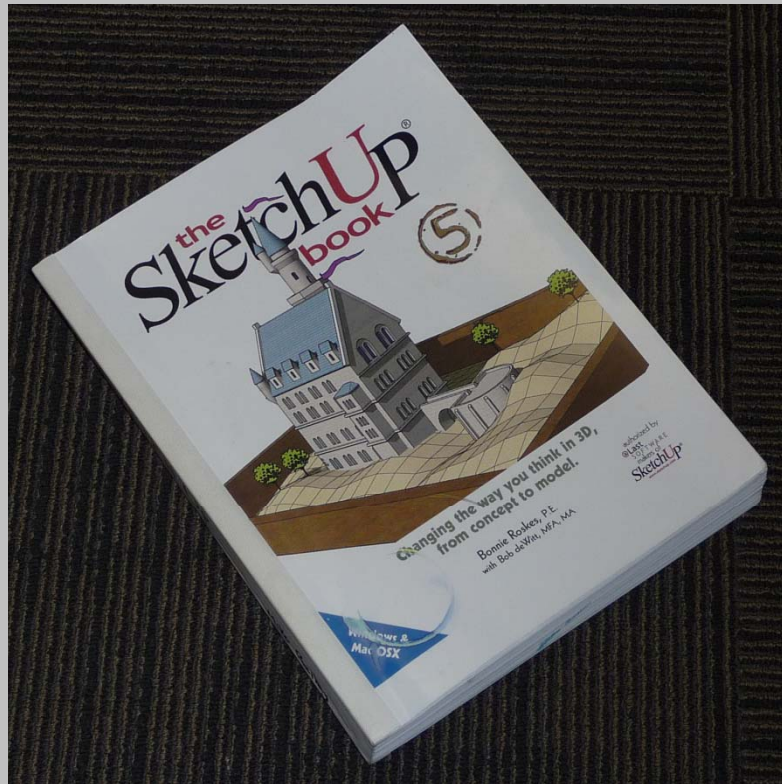

Aidan Chopra, *Google SketchUp for Dummies*.

## Other Examples

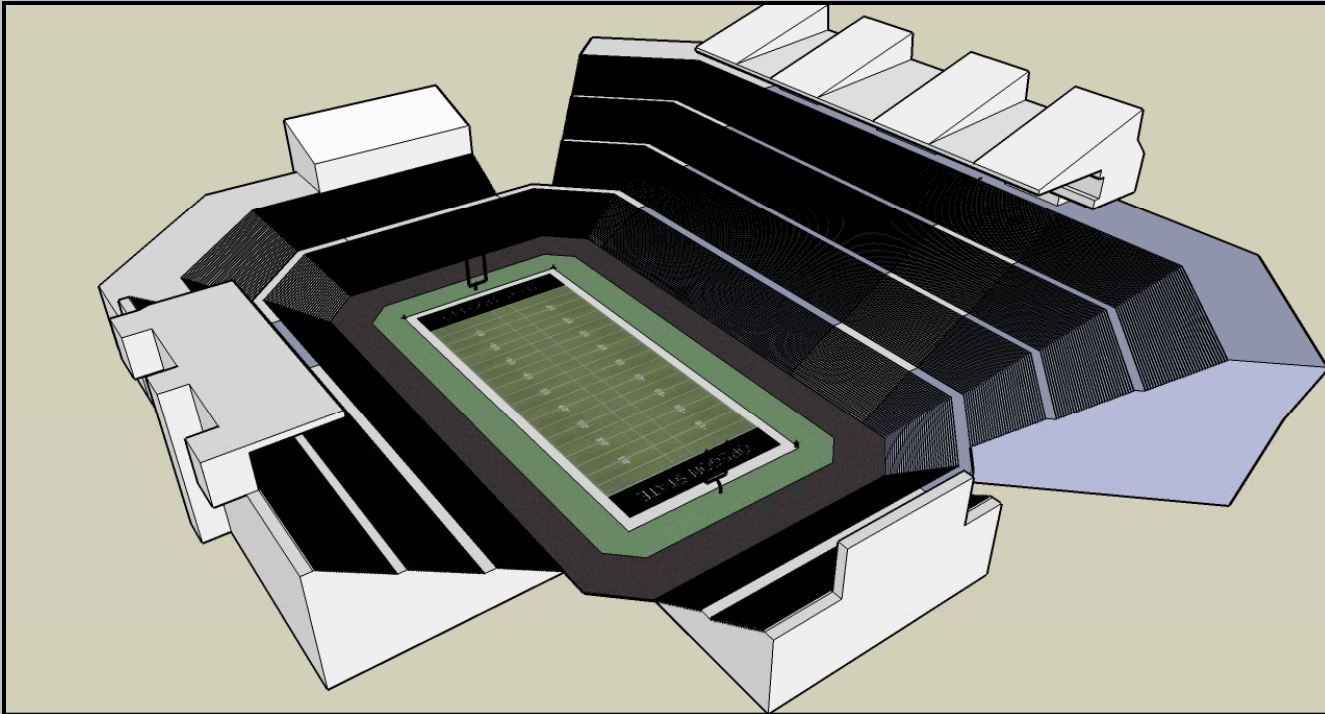

OSU's Reser Stadium, Hassan Sinky

**Select Tool (Spacebar)**  
Ctrl = Add to selection set  
Shift = Toggle in/out of selection set  
Shift+Ctrl = Subtract from selection set  
Ctrl+A = Select all

**Eraser Tool (E)**  
Shift = Hide  
Ctrl = Soften/Smooth  
Shift+Ctrl = Unsoften/Unsmooth

**Rectangle Tool (R)**  
MTB: Length, Width

**Circle Tool (C)**  
Shift = Lock to current orientation  
MTB: Number+s = Segments  
MTB: Number = Radius

**Polygon Tool**  
Shift = Lock to current orientation  
MTB: Number+s = Segments  
MTB: Number = Radius

**Move Tool (M)**  
Shift = Lock to current axis  
Arrow keys = Toggle axis lock  
Ctrl = Toggle copy  
Alt = Toggle auto-fold  
MTB: Number = Distance

**Rotate Tool (Q)**  
Ctrl = Toggle copy  
MTB: Number = Angle  
MTB: Rise:Run = Slope

**Scale Tool (S)**  
Shift = Scale uniformly  
Ctrl = Scale about center  
MTB: Number = Scale factor  
MTB: Number w/ units = Length

**Tape Measure Tool (T)**  
Ctrl = Toggle create construction geom  
Arrow keys = Toggle axis lock  
MTB: Number = Resize model

**Protractor Tool**  
Ctrl = Toggle create construction lines

**Axes Tool**

**Orbit Tool (O)**  
Shift = Pan  
Ctrl = Free

**Zoom Tool (Z)**  
Shift = Change field of view

**Previous**

**Position Camera Tool**

**Walk Tool**

**Paint Bucket Tool (B)**  
Ctrl = Adjacent fill  
Shift = Replace  
Shift+Ctrl = Adjacent replace  
Alt = Sample material

**Make Component (G)**

**Line Tool (L)**  
Shift = Lock to current axis  
Arrow keys = Toggle axis lock  
MTB: Number = Length

**Arc Tool (A)**  
MTB: Number = Bulge  
MTB: Number+s = Segments  
MTB: Number+r = Radius

**Freehand Tool**  
Shift = Draw 3D Polyline

**Push/Pull Tool (P)**  
Ctrl = Toggle new starting face  
Double-Click = Repeat  
MTB: Number = Distance

**Follow Me Tool**  
Alt = Use perimeter of surface as path

**Offset Tool (F)**  
Double-Click: Repeat  
MTB: Number = Length

**Dimension Tool**

**Text Tool**

**3D Text Tool**

**Pan Tool (H)**

**Zoom Extents Tool (Shift+Z)**

**Next**

**Look Around Tool**  
MTB: Number = Eye height

**Section Tool**

Dynamic Components Toolbar

**Interact Tool**

**Component Options**

**Component Attributes**

Google Toolbar

**Get Current View**

**Toggle Terrain**

**Place Model**

**Get Models**

**Share Model**

Face Style Toolbar

**X-Ray**

**Wireframe**

**Hidden Line**

**Shaded**

**Shaded With Textures**

**Monochrome**

Shadows Toolbar

**Display Shadows**

**Shadow Settings**

**Middle Button (Wheel):**  
Click-Drag = Orbit  
Shift-Click-Drag = Pan  
Double-Click = Re-Center View  
Scroll = Zoom

**Left Button:**  
Click = Tool Operation

**Right Button:**  
Click = Context Menu



Sandbox Toolbar

**From Contours Tool**

**From Scratch Tool**

**Smoove Tool**

**Stamp Tool**

**Drape Tool**

**Add Detail Tool**

**Flip Edge Tool**

Views Toolbar

**Iso**

**Top**

**Front**

**Right**

**Back**

**Left**

Layers Toolbar

**Layer Manager**

Sections Toolbar

**Display Section Cuts**

**Display Section Planes**