

The Generic Computer Graphics System

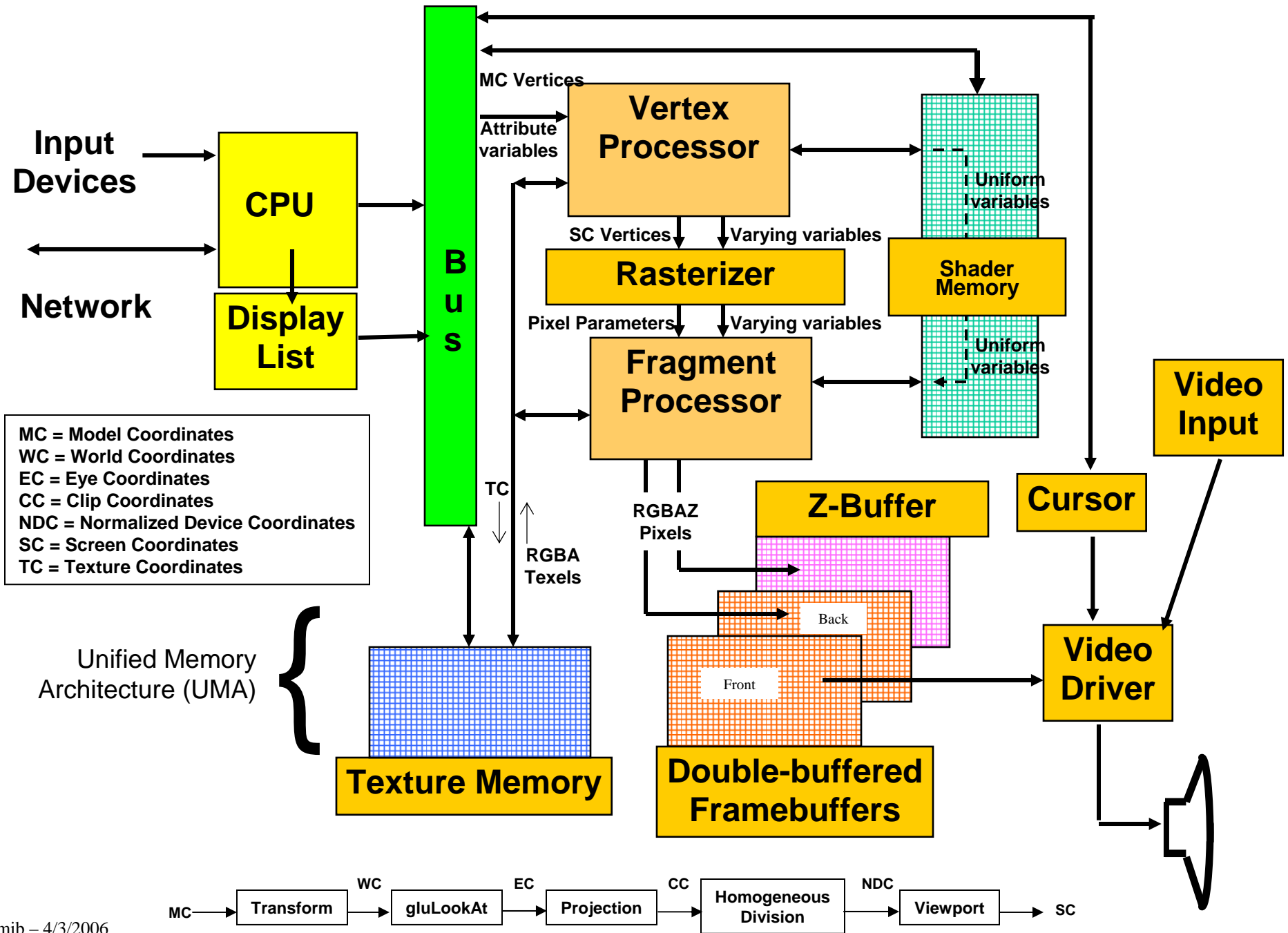

Displaying Color on a Cathode Ray Tube (CRT) Monitor

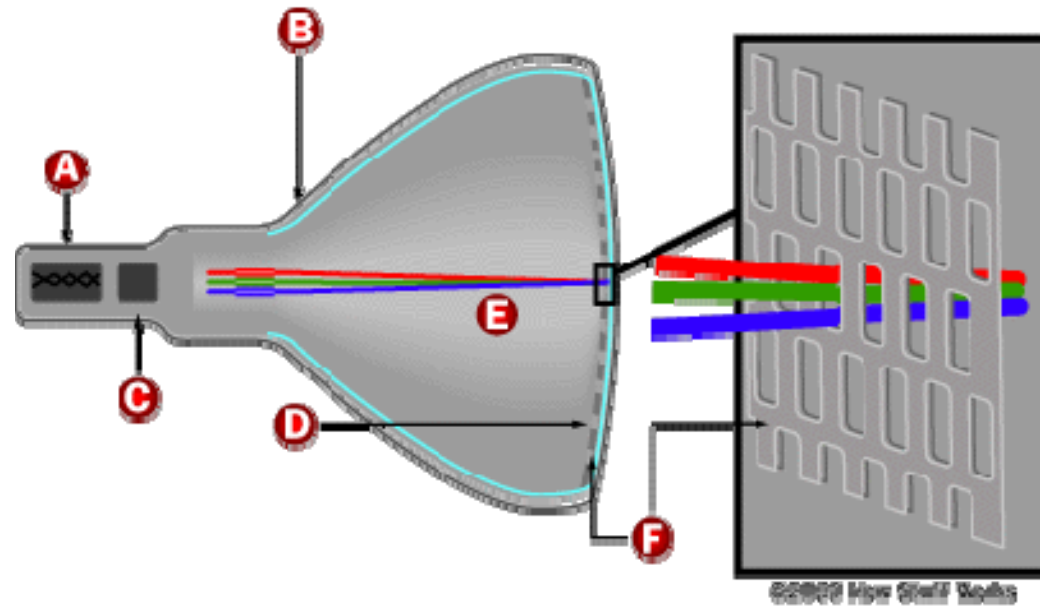

- | | |
|-----------------------------|---------------------------------|
| A Cathode | D Phosphor-coated screen |
| B Conductive coating | E Electron beams |
| C Anode | F Shadow mask |

Source: <http://electronics.howstuffworks.com>

Displaying Color on a Plasma Monitor

- **Gas cell**
- **Phosphor**
- **Grid of electrodes**

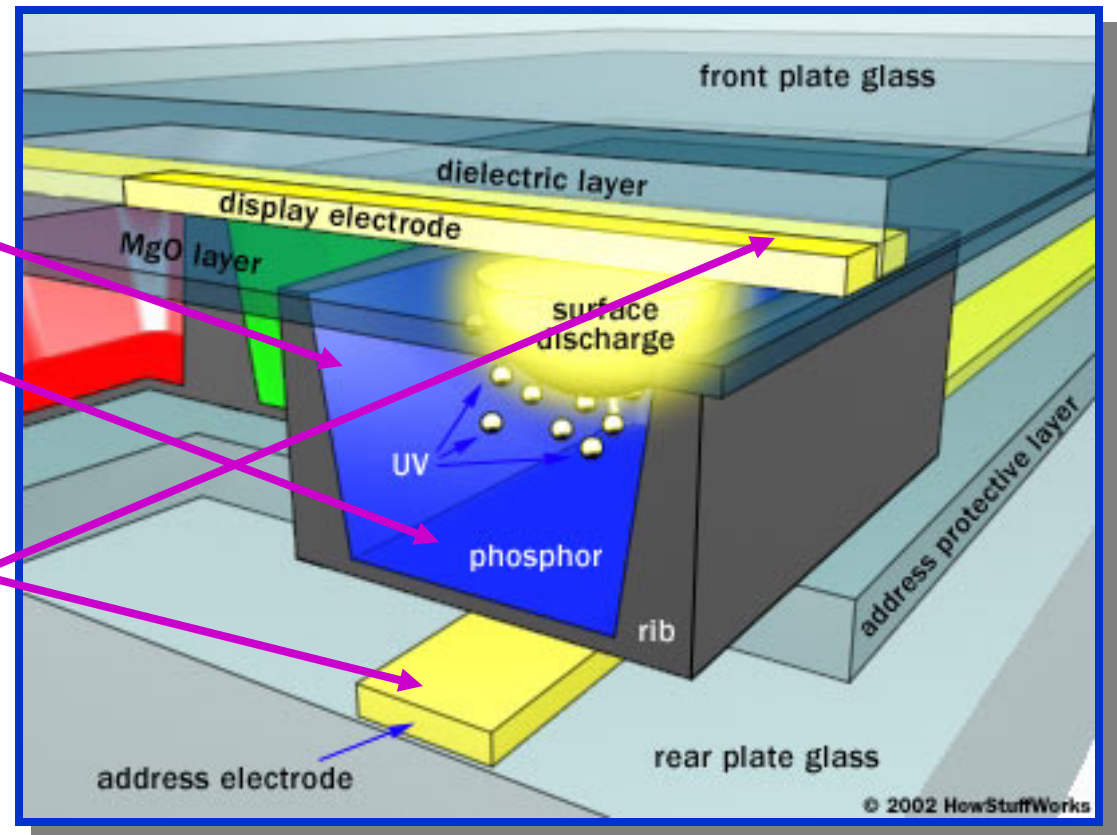

Source: <http://electronics.howstuffworks.com>

Displaying Color on an LCD Monitor

- **Grid of electrodes**

- **Color filters**

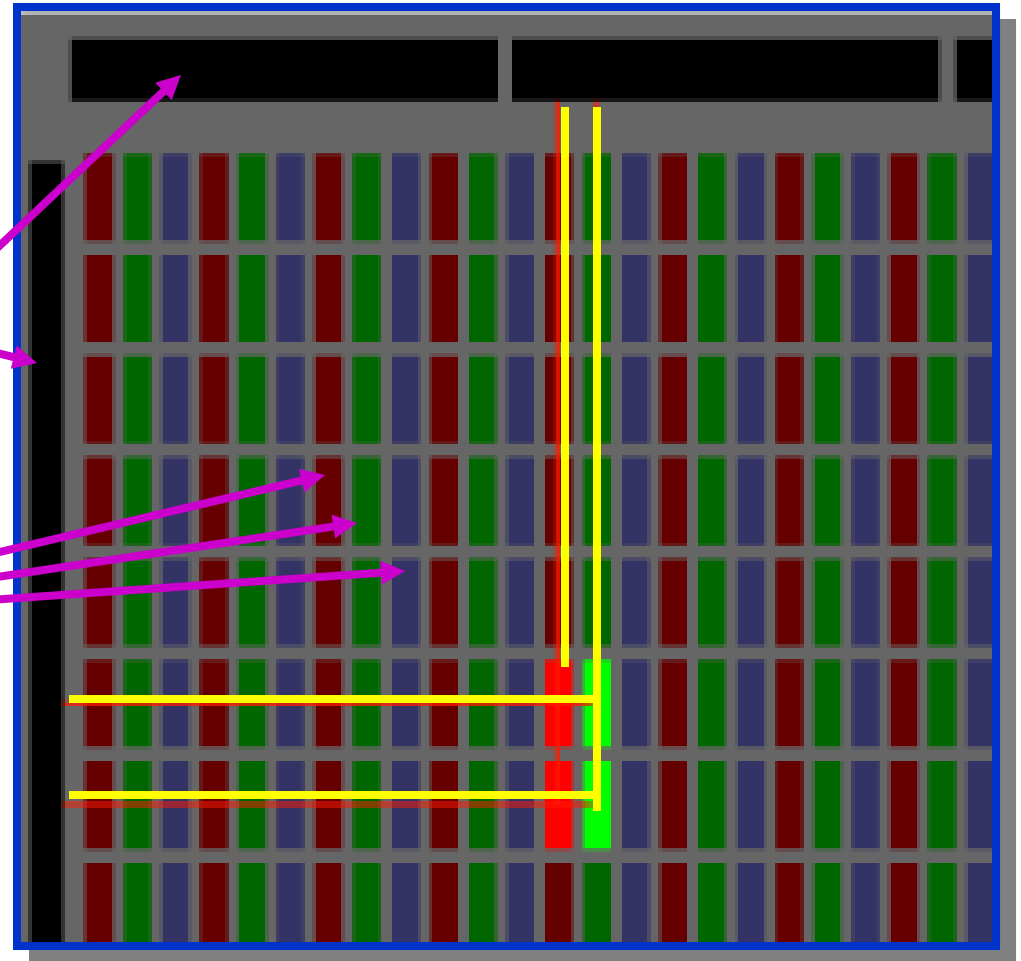

Source: <http://electronics.howstuffworks.com>